

TD

50Hz / 60Hz

Inline Circulation Pumps

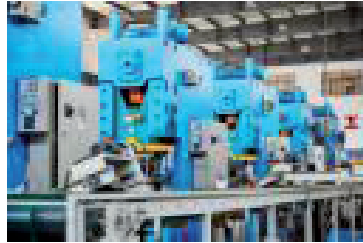



Company profile

Nanfeng Pump Industry Co.,Ltd (CNP),as a subsidiary of Nanfang Zhongjin Environment Co.,Ltd, was founded in 1991,and listed on Shenzhen Stock Exchange on December 9,2010 with stock code 300145.

In 2019, CNP's annual output exceeded 900,000 units/set with nearly 3 billion sales revenue, continuing to maintain high growth.

As a national enterprise technology center, CNP has flagship ultra-high efficient product -new generation CDM (F) light vertical multistage centrifugal pump, $MEI \geq 0.7$. Same series high temperature pump products are developed in 2019 to satisfy high temperature applications. All light stainless steel pump product series grow stably. Advanced frequency conversion water supply equipment has been innovated to the 6th generation. Fire pump and diesel engine have obtained UL certification.TD in-line pump, NIS/NISO end suction pump, NSC split casing pump, WQ sewage pump, PQ stainless steel fountain submersible pump, BP silent tube pump, pool pump, non-blocking self-priming sewage pump, metering pump, oil pump and other pump products, can meet various application needs of different fields.

CNP has a complete sales network both in domestic and overseas market,exporting to over 60 countries and regions, maintaining long-term and strong relationship with our clients. CNP pumps have been widely applied in various fields like water treatment, water supply and drainage, HVAC, industrial application, seawater desalination, energy and power etc.

CNP, a green water expert beside you.

Contents

Performance scope	1
Product range	2
Introduction	8
Model definition	8
Motor	8
Working conditions	8
Applications	8
Min. inlet pressure	9
Max. ambient temperature and altitude	9
Product structure	9
Installation requirements	10
Sectional drawing	11
Curve chart	13
Curve conditions	13
Appendix-base plate	14
TD-32 (50Hz)Performance curve、 performance table、 Installation dimension	16
TD-40 (50Hz)Performance curve、 performance table、 Installation dimension	18
TD-50 (50Hz)Performance curve、 performance table、 Installation dimension	20
TD-65 (50Hz)Performance curve、 performance table、 Installation dimension	24
TD-80 (50Hz)Performance curve、 performance table、 Installation dimension	28
TD-100 (50Hz)Performance curve、 performance table、 Installation dimension	32
TD-125 (50Hz)Performance curve、 performance table、 Installation dimension	34
TD-150 (50Hz)Performance curve、 performance table、 Installation dimension	36
TD-200 (50Hz)Performance curve、 performance table、 Installation dimension	38
TD-250 (50Hz)Performance curve、 performance table、 Installation dimension	42
TD-300 (50Hz)Performance curve、 performance table、 Installation dimension	46
TD-32 (60Hz)Performance curve、 performance table、 Installation dimension	48
TD-40 (60Hz)Performance curve、 performance table、 Installation dimension	50
TD-50 (60Hz)Performance curve、 performance table、 Installation dimension	52
TD-65 (60Hz)Performance curve、 performance table、 Installation dimension	54
TD-80 (60Hz)Performance curve、 performance table、 Installation dimension	56
TD-100 (60Hz)Performance curve、 performance table、 Installation dimension	58
TD-125 (60Hz)Performance curve、 performance table、 Installation dimension	60
TD-150 (60Hz)Performance curve、 performance table、 Installation dimension	62
TD-200 (60Hz)Performance curve、 performance table、 Installation dimension	64
TD-250 (60Hz)Performance curve、 performance table、 Installation dimension	66
TD-300 (60Hz)Performance curve、 performance table、 Installation dimension	68

Performance scope

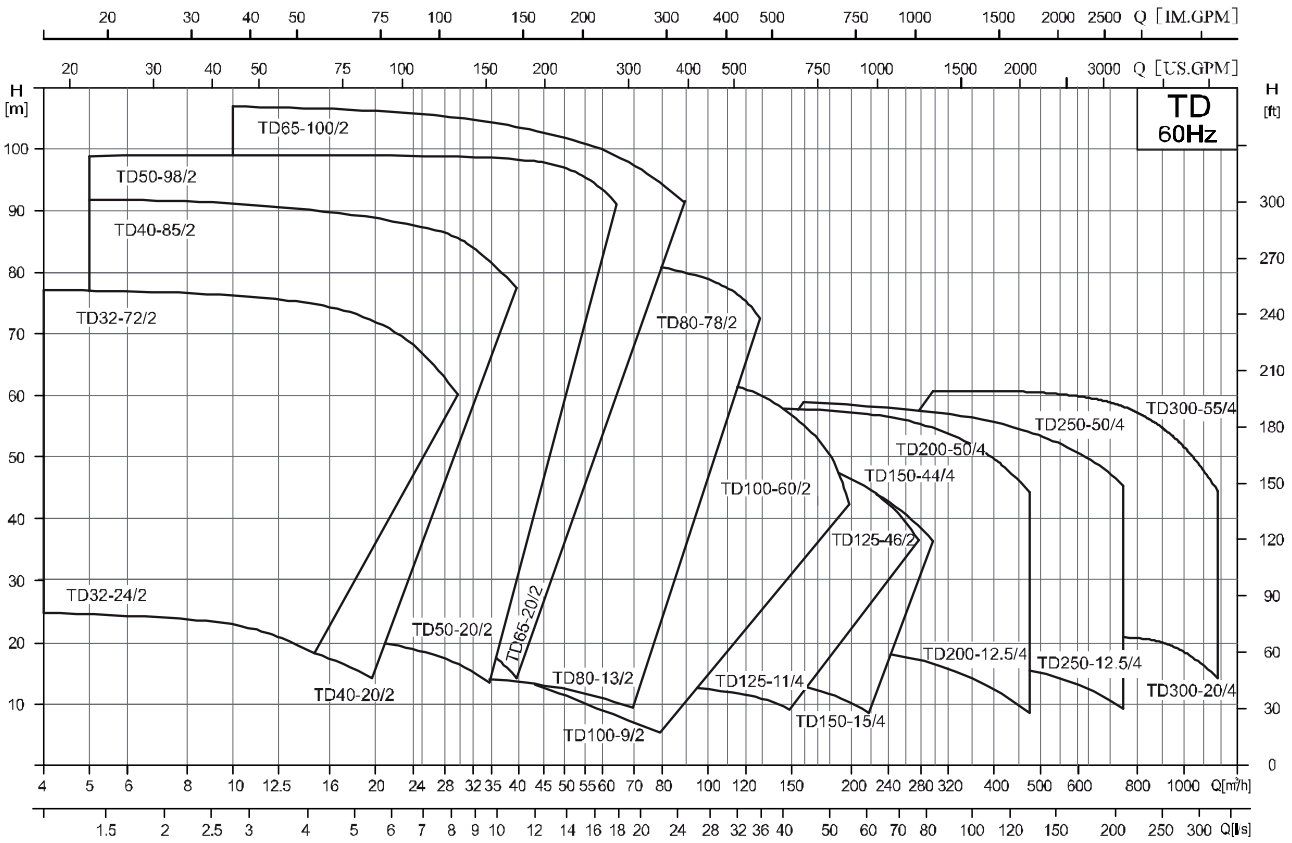
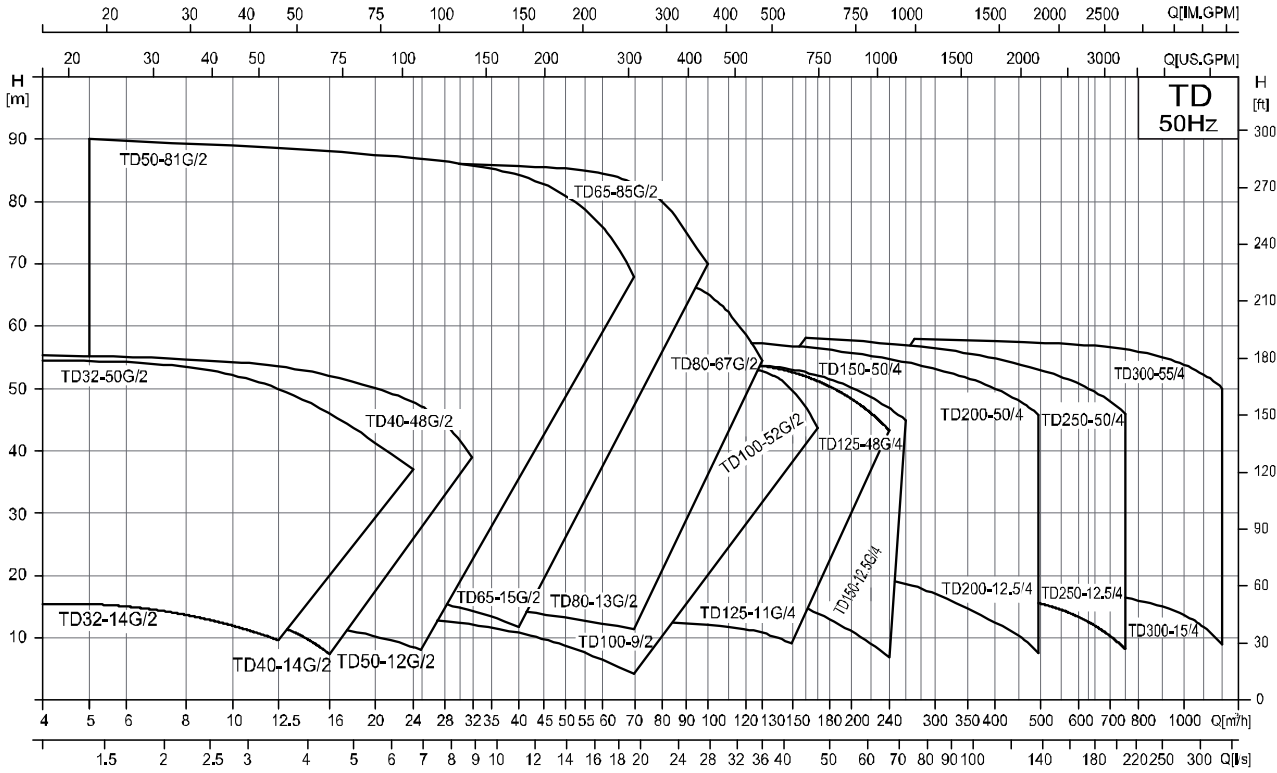

Product range

Table 1

50Hz

NO.	Model	Q [m ³ /h]	H [m]	n [r/min]	Standard voltage [V]	
					1×220V	3×380V
					P2[kW]	P2[kW]
1	TD32-14G/2	8	14	2900	0.75	0.75
2	TD32-18G/2	8	18		1.1	1.1
3	TD32-21G/2	12.5	21		1.5	1.5
4	TD32-26G/2	12.5	26		2.2	2.2
5	TD32-33G/2	12.5	33			3
6	TD32-40G/2	12.5	40			4
7	TD32-50G/2	12.5	50			5.5
8	TD40-14G/2	8	14		0.75	0.75
9	TD40-16G/2	12.5	16		1.1	1.1
10	TD40-21G/2	12.5	21		1.5	1.5
11	TD40-20G/2	20	20		2.2	2.2
12	TD40-26G/2	20	26			3
13	TD40-30G/2	25	30			4
14	TD40-36G/2	25	36			5.5
15	TD40-48G/2	25	48			7.5
16	TD50-32G/2	12.5	32			3
17	TD50-39G/2	12.5	39			4
18	TD50-49G/2	12.5	49			5.5
19	TD50-59G/2	12.5	59			7.5
20	TD50-80G/2	12.5	80			11
21	TD50-12G/2	16	12		1.1	1.1
22	TD50-15G/2	20	15		1.5	1.5
23	TD50-18G/2	25	18		2.2	2.2
24	TD50-24G/2	25	24			3
25	TD50-28G/2	30	28			4
26	TD50-35G/2	30	35			5.5
27	TD50-40G/2	35	40			7.5
28	TD50-50G/2	40	50			11
29	TD50-60G/2	50	60			15
30	TD50-70G/2	50	70			18.5
31	TD50-81G/2	50	81			22
32	TD65-37G/2	25	37			5.5
33	TD65-48G/2	25	48			7.5
34	TD65-15G/2	30	15		2.2	2.2
35	TD65-20G/2	30	20			3
36	TD65-22G/2	40	22			4
37	TD65-30G/2	40	30			5.5
38	TD65-34G/2	50	34			7.5
39	TD65-41G/2	50	41			11
40	TD65-51G/2	50	51			15
41	TD65-61G/2	50	61			18.5

Product range

Table 1(continued)

50Hz

NO.	Model	Q [m ³ /h]	H [m]	n [r/min]	Standard voltage [V]		
					1×220V	3×380V	
					P2[kW]	P2[kW]	
42	TD65-68G/2	50	68	2900		22	
43	TD65-85G/2	50	85			30	
44	TD80-41G/2	50	41			11	
45	TD80-48G/2	50	48			15	
46	TD80-13G/2	50	13			3	
47	TD80-18G/2	50	18			4	
48	TD80-23G/2	50	23			5.5	
49	TD80-29G/2	50	29			7.5	
50	TD80-32G/2	70	32			11	
51	TD80-38G/2	80	38			15	
52	TD80-47G/2	80	47			18.5	
53	TD80-54G/2	80	54			22	
54	TD80-67G/2	80	67			30	
55	TD100-9/2	50	9			2.2	2.2
56	TD100-15/2	60	15				4
57	TD100-17G/2	80	17				5.5
58	TD100-22G/2	80	22				7.5
59	TD100-27/2	100	27				11
60	TD100-33/2	100	33				15
61	TD100-40G/2	100	40				18.5
62	TD100-48G/2	100	48			22	
63	TD100-52G/2	130	52			30	
64	TD125-11G/4	120	11	1450		5.5	
65	TD125-14G/4	120	14			7.5	
66	TD125-19G/4	140	19	1480		11	
67	TD125-22G/4	160	22			15	
68	TD125-28G/4	160	28			18.5	
69	TD125-32G/4	160	32			22	
70	TD125-40G/4	160	40			30	
71	TD125-48G/4	160	48			37	
72	TD150-12.5G/4	200	12.5			11	
73	TD150-17G/4	200	17			15	
74	TD150-22G/4	200	22			18.5	
75	TD150-25/4	200	25			22	
76	TD150-33/4	200	33		30		
77	TD150-40/4	200	40		37		
78	TD150-50/4	200	50		45		
79	TD200-16/4	300	16		18.5		
80	TD200-19/4	300	19		22		
81	TD200-24/4	300	24		30		
82	TD200-31/4	300	31		37		

Product range

Table 1(continued)

50Hz

NO.	Model	Q [m ³ /h]	H [m]	n [r/min]	Standard voltage [V]	
					1×220V	3×380V
					P2[kW]	P2[kW]
83	TD200-36/4	300	36	1480		45
84	TD200-47/4	300	47			55
85	TD200-53/4	300	53			75
86	TD200-12.5/4	400	12.5			22
87	TD200-20/4	400	20			30
88	TD200-23/4	400	23			37
89	TD200-27/4	400	27			45
90	TD200-32/4	400	32			55
91	TD200-43/4	400	43			75
92	TD200-50/4	400	50			90
93	TD250-16/4	500	16			30
94	TD250-19/4	500	19			37
95	TD250-22/4	500	22			45
96	TD250-29/4	500	29			55
97	TD250-36/4	500	36			75
98	TD250-47/4	500	47			90
99	TD250-56/4	500	56			110
100	TD250-12.5/4	630	12.5			30
101	TD250-14/4	630	14			37
102	TD250-17/4	630	17			45
103	TD250-20/4	630	20			55
104	TD250-26/4	630	26			75
105	TD250-32/4	630	32			90
106	TD250-40/4	630	40			110
107	TD250-50/4	630	50			132
108	TD300-15/4	900	15			55
109	TD300-20/4	900	20			75
110	TD300-25/4	900	25			90
111	TD300-30/4	900	30			110
112	TD300-35/4	900	35			132
113	TD300-44/4	900	44		160	
114	TD300-55/4	900	55		200	

Product range

Table 2

60Hz

NO.	Model	Q [m ³ /h]	H [m]	n [r/min]	Standard voltage [V]		
					1×220V	3×380V	
					P2[kW]	P2[kW]	
1	TD32-24/2	7	24	3500	1.5	1.5	
2	TD32-27/2	10	27		2.2	2.2	
3	TD32-30/2	15	30			3	
4	TD32-38/2	15	38			4	
5	TD32-46/2	15	46			5.5	
6	TD32-57/2	20	57			7.5	
7	TD32-72/2	20	72			11	
8	TD40-20/2	12	20			1.5	1.5
9	TD40-24/2	15	24			2.2	2.2
10	TD40-28/2	15	28				3
11	TD40-32/2	20	32				4
12	TD40-35/2	25	35				5.5
13	TD40-42/2	25	42				7.5
14	TD40-65/2	25	65				11
15	TD40-76/2	25	76				15
16	TD40-85/2	30	85				18.5
17	TD50-20/2	20	20			2.2	2.2
18	TD50-27/2	20	27				3
19	TD50-34/2	20	34				4
20	TD50-40/2	20	40				5.5
21	TD50-42/2	30	42				7.5
22	TD50-51/2	35	51				11
23	TD50-62/2	45	62				15
24	TD50-72/2	45	72				18.5
25	TD50-84/2	45	84				22
26	TD50-98/2	50	98				30
27	TD65-20/2	30	20				3
28	TD65-25/2	30	25				4
29	TD65-32/2	30	32				5.5
30	TD65-38/2	35	38				7.5
31	TD65-46/2	35	46				11
32	TD65-55/2	35	55				15
33	TD65-60/2	50	60				18.5
34	TD65-73/2	50	73				22
35	TD65-85/2	60	85				30
36	TD65-100/2	60	100				37
37	TD80-12/2	50	12				3
38	TD80-17/2	50	17				4
39	TD80-20/2	60	20				5.5
40	TD80-26/2	60	26				7.5
41	TD80-30/2	80	30				11

Product range

Table 2(continued)

60Hz

NO.	Model	Q [m ³ /h]	H [m]	n [r/min]	Standard voltage [V]		
					1×220V	3×380V	
					P2[kW]	P2[kW]	
42	TD80-38/2	80	38	3500		15	
43	TD80-47/2	80	47			18.5	
44	TD80-52/2	80	52			22	
45	TD80-70/2	80	70			30	
46	TD80-81/2	80	81			37	
47	TD100-11/2	50	11			3	
48	TD100-15/2	60	15			4	
49	TD100-17/2	80	17			5.5	
50	TD100-22/2	80	22			7.5	
51	TD100-25/2	100	25			11	
52	TD100-32/2	100	32			15	
53	TD100-34/2	120	34			18.5	
54	TD100-38/2	120	38			22	
55	TD100-52/2	130	52			30	
56	TD100-60/2	130	60			37	
57	TD125-11/4	120	11		1750		5.5
58	TD125-14/4	120	14				7.5
59	TD125-20/4	120	20				11
60	TD125-24/4	120	24				15
61	TD125-28/4	140	28				18.5
62	TD125-32/4	150	32			22	
63	TD125-38/4	150	38			30	
64	TD125-40/4	180	40			37	
65	TD125-46/4	180	46			45	
66	TD150-15/4	160	15			11	
67	TD150-18/4	180	18			15	
68	TD150-20/4	200	20			18.5	
69	TD150-24/4	200	24			22	
70	TD150-32/4	200	32			30	
71	TD150-36/4	200	36			37	
72	TD150-44/4	400	44			45	
73	TD200-12.5/4	400	12.5			22	
74	TD200-20/4	400	20			30	
75	TD200-23/4	400	23			37	
76	TD200-27/4	400	27			45	
77	TD200-32/4	400	32		55		
78	TD200-43/4	400	43		75		
79	TD200-50/4	630	50		90		
80	TD250-14/4	630	14		37		
81	TD250-17/4	630	17		45		
82	TD250-20/4	630	20		55		

Product range

Table 2(continued)

60Hz

NO.	Model	Q [m ³ /h]	H [m]	n [r/min]	Standard voltage [V]	
					1×220V	3×380V
					P2[kW]	P2[kW]
83	TD250-26/4	630	26	1750		75
84	TD250-32/4	630	32			90
85	TD250-40/4	630	40			110
86	TD250-50/4	630	50			132
87	TD300-20/4	900	20			75
88	TD300-25/4	900	25			90
89	TD300-30/4	900	30			110
90	TD300-35/4	900	35			132
91	TD300-44/4	900	44			160
92	TD300-55/4	900	55			200

Introduction

TD pumps are single-stage in-line circulation pumps, equipped with standard motor and mechanical seal. Comparing with other pumps in similar structure, these pumps are less accessible to the impurity in the liquid.

TD pumps are designed to be pulled out from the top when disassemble. It can be repaired without affecting the pipeline.

The mechanical seal for TD200 and above is cartridge mechanical seal. Motor needn't to be disassembled when replace mechanical seal.

Model definition

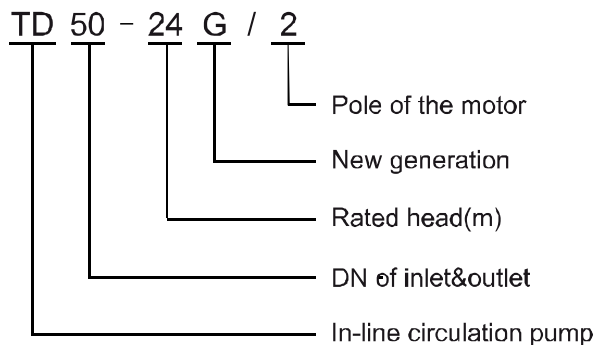

Motor

2 Pole,4 Pole TEFC motor

Protection level: IP55

Insulation grade: F

Standard power: 50Hz: 1×220-230/240V

3×200-220/346-380V

3×220-240/380-415V

60Hz: 3×200-230/346-400V

3×200-255/380-440V

3×220-277/380-485V

Working conditions

This product is applied for thin, clean, non-flammable, non-explosive, solid free, fiber free, physically and chemically water-like liquid. The performance curve will descend and energy consumption will be increased if the liquid viscosity or density is beyond the required level.

Max. working pressure: 12 bar for normal type, 16 bar for special type

Liquid temperature: -15°C to 110°C

Ambient temperature: up to 40°C

Altitude: up to 1000m

Rotation direction: clockwise (looking down from motor fan)

Applications

TD pump is a versatile product that can transport various media from tap water to industrial liquids, mainly used for liquid conveying, pressurizing and circulating equipment. For example:

District heating system (the water quality in the heating system should meet the recognized water quality standards of that kind of system)

HVAC system

Cooling system

Domestic hot water system

Industrial liquid transportation

Water supply system

Minimum inlet pressure NPSH

In case that the pressure in pump is lower than the steam pressure used to convey liquid, the cavitations will occur. To avoid cavitations, a minimum pressure at the inlet side of the pump shall be guaranteed. The maximum suction can be calculated with the following formula:

$$H = P_b \times 10.2 - NPSH - H_f - H_v - H_s$$

H—Maximum suction head(m)

P_b—Atmosphere pressure(bar)

In a closed system, P_b means system pressure(bar)

NPSH—Net positive suction head(m)

It can be read from the point of Max. flow rate shown on NPSH curve.

H_f—Pipeline loss at the inlet(m)

It is in accordance with the pipeline possible Max. flow.

H_v—Steam pressure(m)

It depends on liquid temperature and steam pressure value.

H_s—Safety margin(m)

Minimum 0.5m delivery head.

If the calculated result H is negative, the pump may run under the Max. suction head H. In case the calculated result H is negative, a delivery head of Min. inlet pressure is necessary.

NOTE: Normally, the above calculation will not be done.

H is calculated in the following conditions:

1. The liquid temperature is comparatively higher;
2. Liquid flow exceeds rated value;
3. Suction head is comparatively large or inlet pipeline long;
4. System pressure is too low;
5. Bad inlet condition.

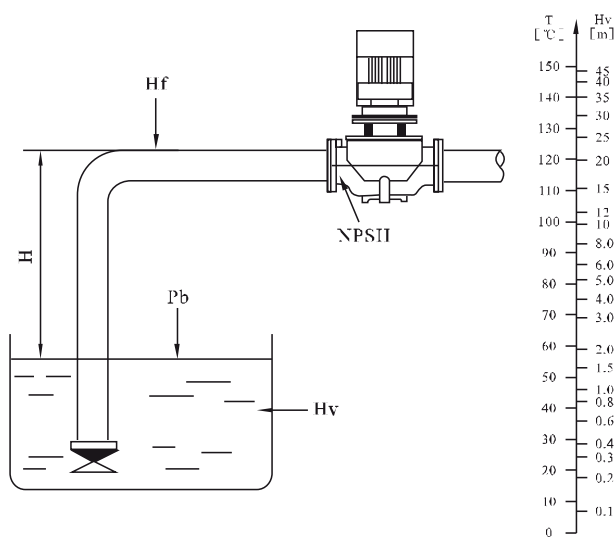

Maximum ambient temperature and altitude

When the pump is operating under ambient temperature higher than 40°C or altitude higher than 1000 m, the motor output power will be reduced due to the low air density and poor cooling effect. Motor power needs to be increased when pump running under the above condition.

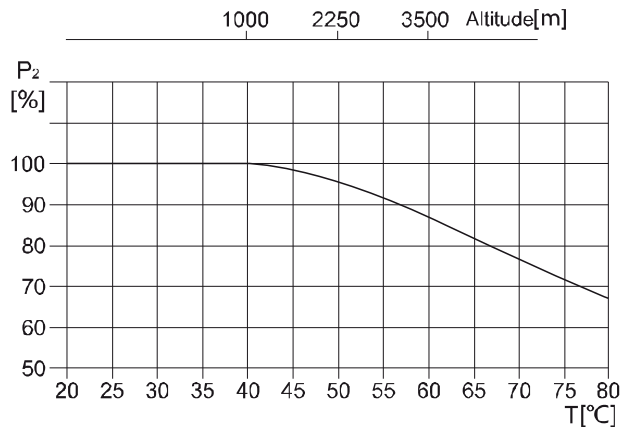

Product structure

The design of the pump is pump and motor. Pump part can be pulled out. TD series are equipped with standard motor and mechanical seal. Motor is TEFC standard motor.

The pump body is equal to a section of pipeline. While in maintenance, blind flange can be used to seal to pump cover which enable to the normal operation of pumps.

The flange connection dimension are in conformity with the related provisions PN16 in GB/T 17241.6 or ISO7005-2.

The inlet and outlet diameters are in conformity with related standard dimensions.

The pump head is to connect motor and the pump. O ring is used to seal the pump head and the pump.

Installation requirements

TD pumps have different installation requirements. The details are as below.

1. If the system pipeline can support the pumps, pumps with 2.2KW motor power (including 2.2KW) can be hung in line; if the system pipeline cannot support the pumps or the pump motor power is higher than 2.2KW, the pump must be installed in brackets or base.

2. Pumps with motor power lower than 2.2KW (including 2.2KW) can be installed horizontally or vertically to the pipeline. Pumps with motor power higher than 2.2KW, can only be installed vertically to the pipeline. (see Figure 2-A)

3. The pump installation shall not allow the system pipeline tensile force to be transferred to the pump body.

4. The pumps should be installed in the environment with sufficient cooling and the cooling air shall not be above 40°C.

5. If the pumps are installed outdoors, there should be covers to protect electric components from water.

6. For the convenience of maintenance, there should be enough space above and below the pumps. Minimum 300mm shall be kept for pumps with motor power lower than 5.5KW, and minimum 1000mm for pumps with motor power higher than 5.5KW (including 5.5KW) (see Figure 2-B)

7. To prevent noises and vibration and ensure the best operation, anti-vibration base shall be used in installation. Generally, cement base with the weight equal or bigger than 1.5×pump weight shall be adopted. (see Figure 2-C)

8. For TD32 to TD150, pumps with bases or without bases are both available for customers requirements. (See appendix TD32-TD150 for base dimensions)

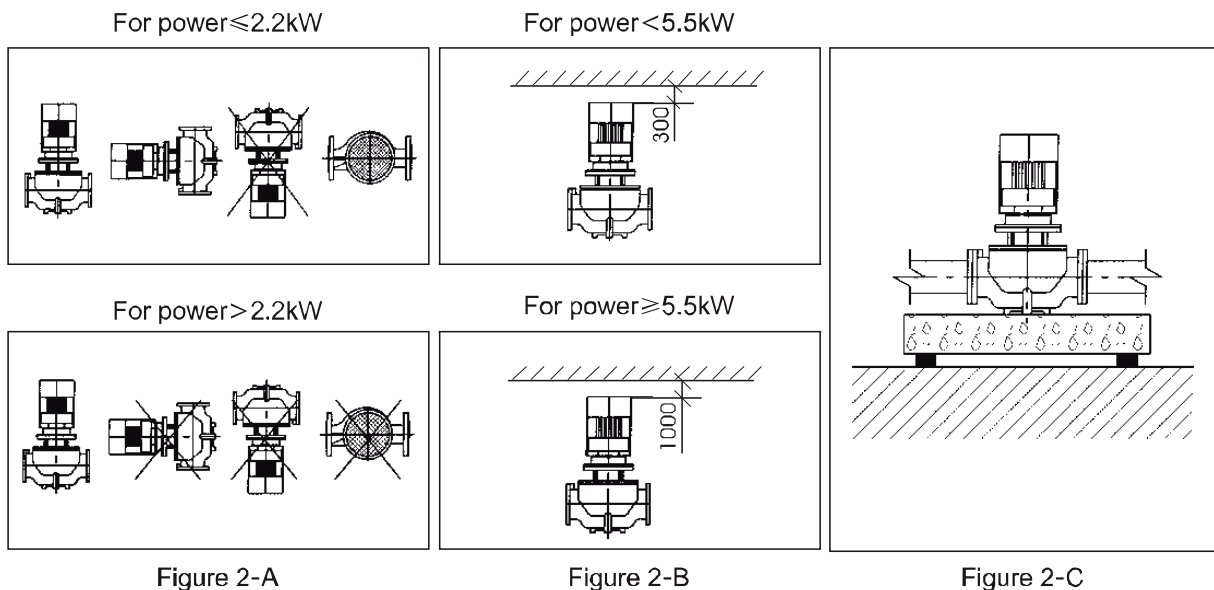

Sectional drawing of TD32-TD150 Extension Shaft

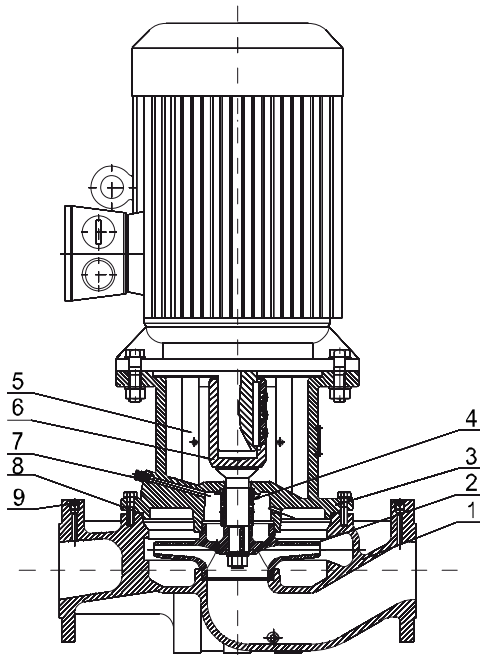

Sectional drawing of TD200-250 easy maintenance structure

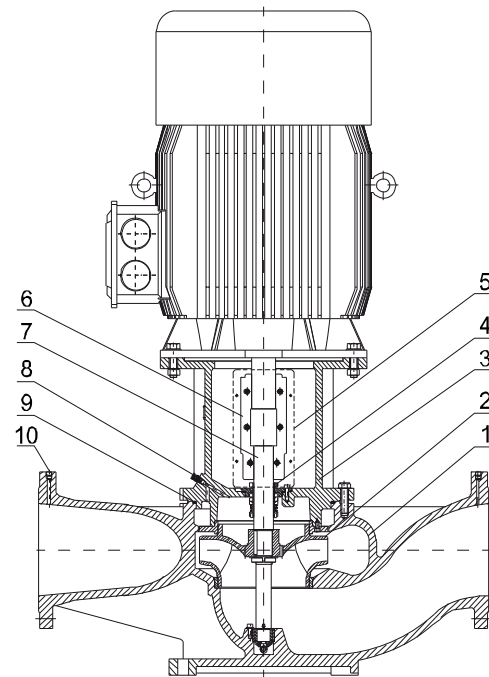

Material list of TD32-TD150

NO.	Parts	Material
1	Pump body	HT200
2	Impeller	HT200/ZG07Cr19Ni9
3	Pump head	HT200
4	Mechanical seal	Carbon/Silicon Carbide
5	Guard plate	06Cr19Ni10
6	Shaft	20Cr13
7	Air release bolt	06Cr19Ni10
8	O-ring	NBR
9	Plug	06Cr19Ni10

Material list of TD200-TD250

NO.	Parts	Material
1	Pump body	HT200
2	Impeller	HT200/ZG07Cr19Ni9
3	Pump head	HT200
4	Mechanical seal	Carbon/Silicon Carbide
5	Guard plate	06Cr19Ni10
6	Coupling	Cast Steel ZG270-500
7	Shaft	20Cr13
8	Air release bolt	06Cr19Ni10
9	O-ring	NBR
10	Plug	06Cr19Ni10

Sectional drawing of TD300 easy maintenance structure

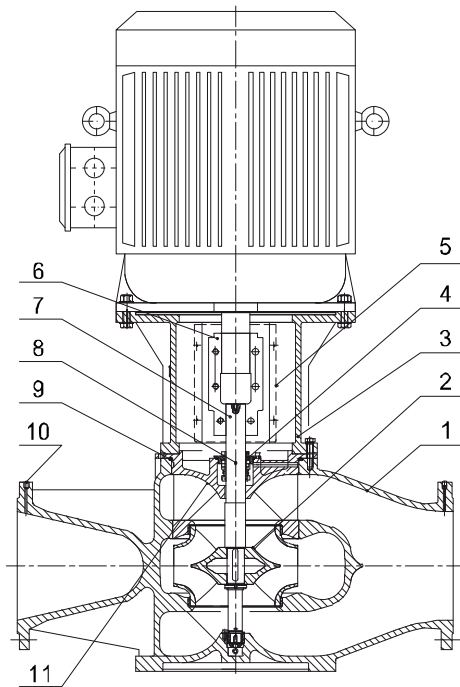

Material list of TD300

NO.	Parts	Material
1	Pump body	QT500-7
2	Impeller	HT200/ZG07Cr19Ni9
3	Pump head	HT200
4	Mechanical seal	Carbon/Silicon Carbide
5	Guard plate	06Cr19Ni10
6	Coupling	Cast Steel ZG270-500
7	Shaft	20Cr13
8	Air release bolt	06Cr19Ni10
9	O-ring	NBR
10	Plug	06Cr19Ni10
11	Pump cover	QT500-7

Curve chart

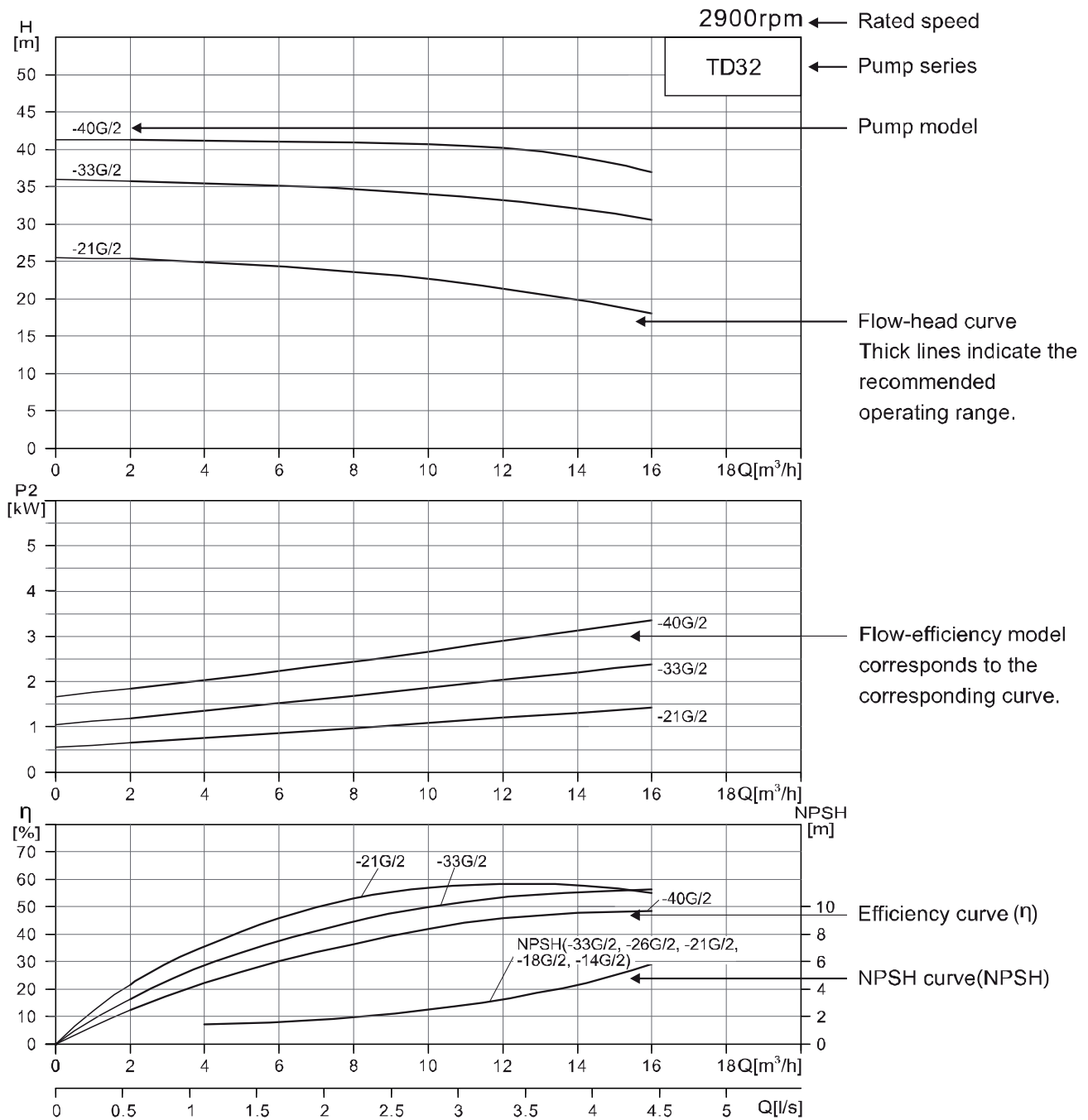

Curve conditions

Following conditions are suitable for the performance curves shown above.

1. All curves are based on the measured values of motor 3×380V, 50Hz: under the constant speed of 2900rpm, 1450rpm or 1480rpm; 60Hz: under the constant speed of 3500rpm, 1750rpm.

2. Curve tolerance in conformity with ISO9906:2012, Grade 3B.

3. Measurement is done with 20°C air-free water, without impurities.

4. The operation of pump shall refer to the performance region indicated by the thickened curve to prevent overheating due to too small flow rate or overload of motor due to too large flow rate.

5. If the thickness and density of the pumped liquid is different from water, the motor power should be adjusted.

Appendix-Base plate

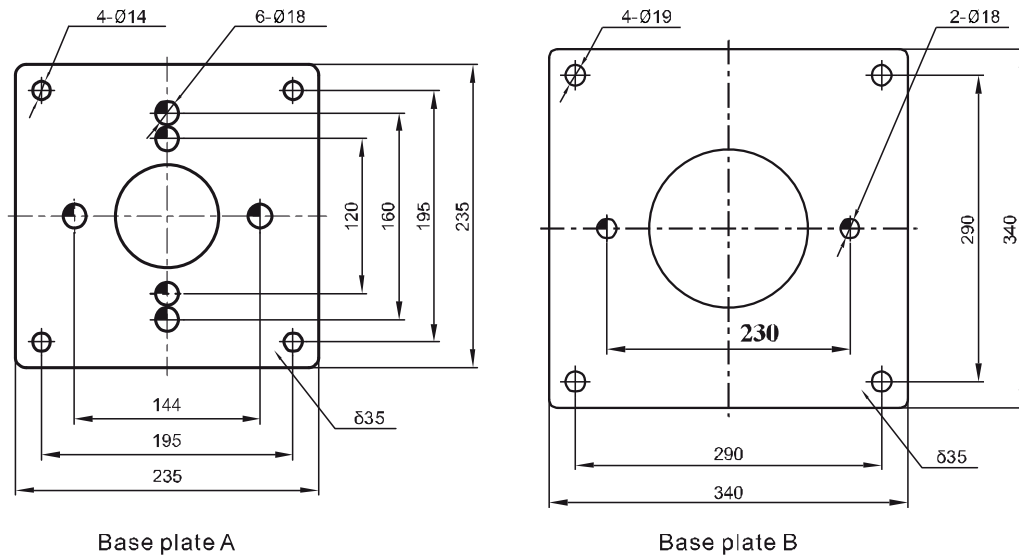

Base plate A

Base plate B

50Hz

NO.	Product model	Base plate type	NO.	Product model	Base plate type	NO.	Product model	Base plate type
1	TD32-14G/2	A	27	TD50-40G/2	A	53	TD80-54G/2	A
2	TD32-18G/2	A	28	TD50-50G/2	A	54	TD80-67G/2	A
3	TD32-21G/2	A	29	TD50-60G/2	A	55	TD100-9/2	A
4	TD32-26G/2	A	30	TD50-70G/2	A	56	TD100-15/2	A
5	TD32-33G/2	A	31	TD50-81G/2	A	57	TD100-17G/2	A
6	TD32-40G/2	A	32	TD65-37G/2	A	58	TD100-22G/2	A
7	TD32-50G/2	A	33	TD65-48G/2	A	59	TD100-27/2	A
8	TD40-14G/2	A	34	TD65-15G/2	A	60	TD100-33/2	A
9	TD40-16G/2	A	35	TD65-20G/2	A	61	TD100-40G/2	B
10	TD40-21G/2	A	36	TD65-22G/2	A	62	TD100-48G/2	B
11	TD40-20G/2	A	37	TD65-30G/2	A	63	TD100-52G/2	B
12	TD40-26G/2	A	38	TD65-34G/2	A	64	TD125-11G/4	B
13	TD40-30G/2	A	39	TD65-41G/2	A	65	TD125-14G/4	B
14	TD40-36G/2	A	40	TD65-51G/2	A	66	TD125-19G/4	B
15	TD40-48G/2	A	41	TD65-61G/2	A	67	TD125-22G/4	B
16	TD50-32G/2	A	42	TD65-68G/2	A	68	TD125-28G/4	B
17	TD50-39G/2	A	43	TD65-85G/2	A	69	TD125-32G/4	B
18	TD50-49G/2	A	44	TD80-41G/2	A	70	TD125-40G/4	B
19	TD50-59G/2	A	45	TD80-48G/2	A	71	TD125-48G/4	B
20	TD50-80G/2	A	46	TD80-13G/2	A	72	TD150-12.5G/4	B
21	TD50-12G/2	A	47	TD80-18G/2	A	73	TD150-17G/4	B
22	TD50-15G/2	A	48	TD80-23G/2	A	74	TD150-22G/4	B
23	TD50-18G/2	A	49	TD80-29G/2	A	75	TD150-25/4	B
24	TD50-24G/2	A	50	TD80-32G/2	A	76	TD150-33/4	B
25	TD50-28G/2	A	51	TD80-38G/2	A	77	TD150-40/4	B
26	TD50-35G/2	A	52	TD80-47G/2	A	78	TD150-50/4	B

Remark: Base plate is optional part, need to note when order.

60Hz

NO.	Product model	Base plate type	NO.	Product model	Base plate type	NO.	Product model	Base plate type
1	TD32-24/2	A	25	TD50-84/2	A	49	TD100-17/2	A
2	TD32-27/2	A	26	TD50-98/2	A	50	TD100-22/2	A
3	TD32-30/2	A	27	TD65-20/2	A	51	TD100-25/2	B
4	TD32-38/2	A	28	TD65-25/2	A	52	TD100-32/2	B
5	TD32-46/2	A	29	TD65-32/2	A	53	TD100-34/2	B
6	TD32-57/2	A	30	TD65-38/2	A	54	TD100-38/2	B
7	TD32-72/2	A	31	TD65-46/2	A	55	TD100-52/2	B
8	TD40-20/2	A	32	TD65-55/2	A	56	TD100-60/2	B
9	TD40-24/2	Δ	33	TD65-60/2	Δ	57	TD125-11/4	B
10	TD40-28/2	A	34	TD65-73/2	A	58	TD125-14/4	B
11	TD40-32/2	A	35	TD65-85/2	A	59	TD125-20/4	B
12	TD40-35/2	A	36	TD65-100/2	A	60	TD125-24/4	B
13	TD40-42/2	A	37	TD80-12/2	A	61	TD125-28/4	B
14	TD40-65/2	A	38	TD80-17/2	A	62	TD125-32/4	B
15	TD40-76/2	A	39	TD80-20/2	A	63	TD125-38/4	B
16	TD40-85/2	A	40	TD80-26/2	A	64	TD125-40/4	B
17	TD50-20/2	A	41	TD80-30/2	A	65	TD125-46/4	B
18	TD50-27/2	A	42	TD80-38/2	A	66	TD150-15/4	B
19	TD50-34/2	Δ	43	TD80-47/2	Δ	67	TD150-18/4	B
20	TD50-40/2	Δ	44	TD80-52/2	Δ	68	TD150-20/4	B
21	TD50-42/2	A	45	TD80-70/2	A	69	TD150-24/4	B
22	TD50-51/2	A	46	TD80-81/2	A	70	TD150-32/4	B
23	TD50-62/2	A	47	TD100-11/2	A	71	TD150-36/4	B
24	TD50-72/2	A	48	TD100-15/2	A	72	TD150-44/4	B

Remark: Base plate is optional part, need to note when order.

Performance curve

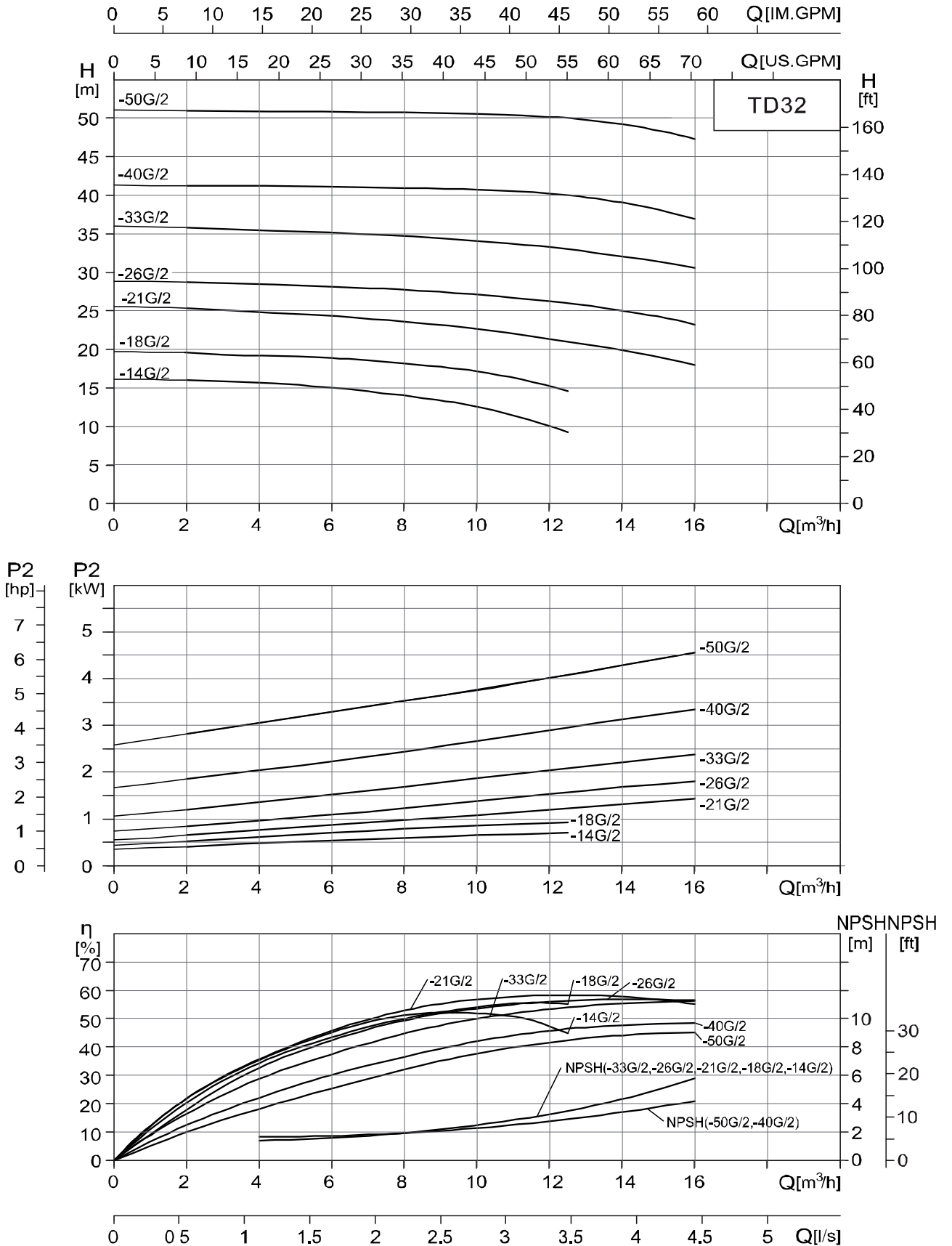

TD32 Performance table

50Hz

Model	Motor (kW)	Q (m³/h)	2	4	6	8	10	12.5	14	16
TD32-14G/2	0.75	H (m)	16	15.7	15.1	14	12.6	9.3		
TD32-18G/2	1.1		19.6	19.3	18.9	18	17.2	14.6		
TD32-21G/2	1.5		25.3	24.9	24.3	23.6	22.6	21	19.9	18
TD32-26G/2	2.2		28.7	28.4	28.1	27.7	27.1	26	25	23.2
TD32-33G/2	3		35.8	35.5	35.1	34.7	34.1	33	32.1	30.6
TD32-40G/2	4		41.3	41.2	41.1	41	40.7	40	39.1	37
TD32-50G/2	5.5		51	50.9	50.8	50.7	50.5	50	49.2	47.3

Installation sketch

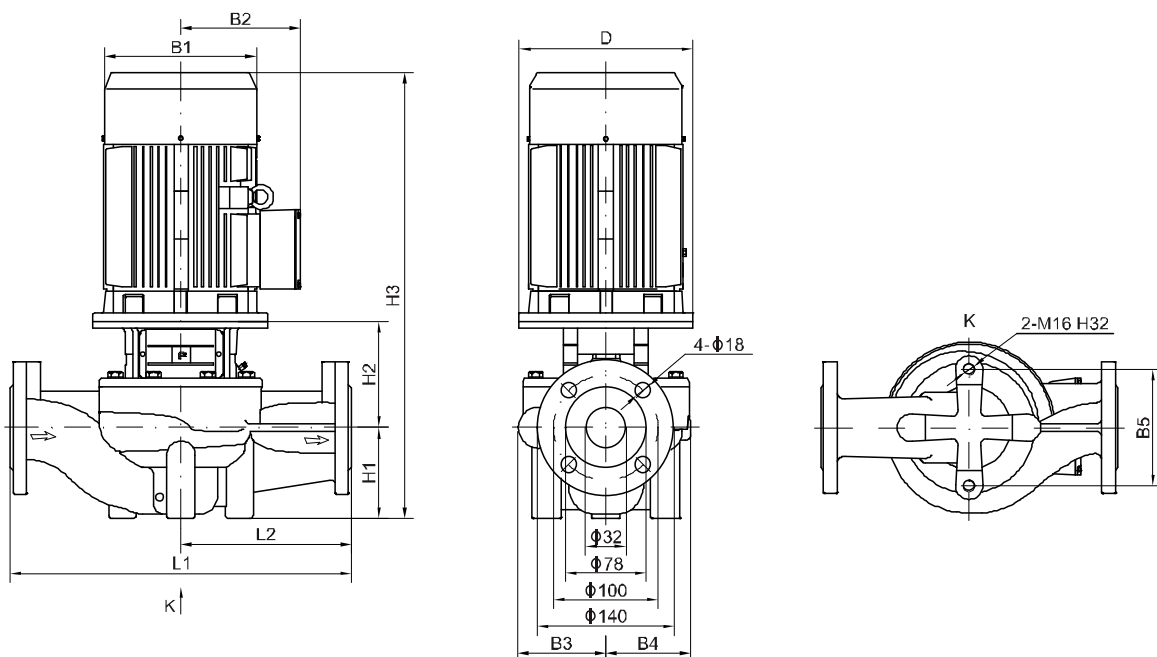

Dimensions and weights

Model	Dimension(mm)											Weight (kg)
	D	B1	B2	B3	B4	B5	H1	H2	H3	L1	L2	
TD32-14G/2	120	151	125	101	101	144	90	135	469	320	160	33
TD32-18G/2	120	151	125	101	101	144	90	135	469	320	160	34
TD32-21G/2	140	171	137	101	101	144	90	137	514	320	160	38
TD32-26G/2	140	171	137	101	101	144	90	137	514	320	160	42
TD32-33G/2	160	196	150	109	109	144	90	145	572	340	170	52
TD32-40G/2	160	214	169	128	128	144	100	151	593	360	180	65
TD32-50G/2	200	257	190	128	128	144	100	173	656	360	180	84

Note: The dimension of single-phase motor and explosion-proof motor will change. Please consult our company for more details.

Performance curve

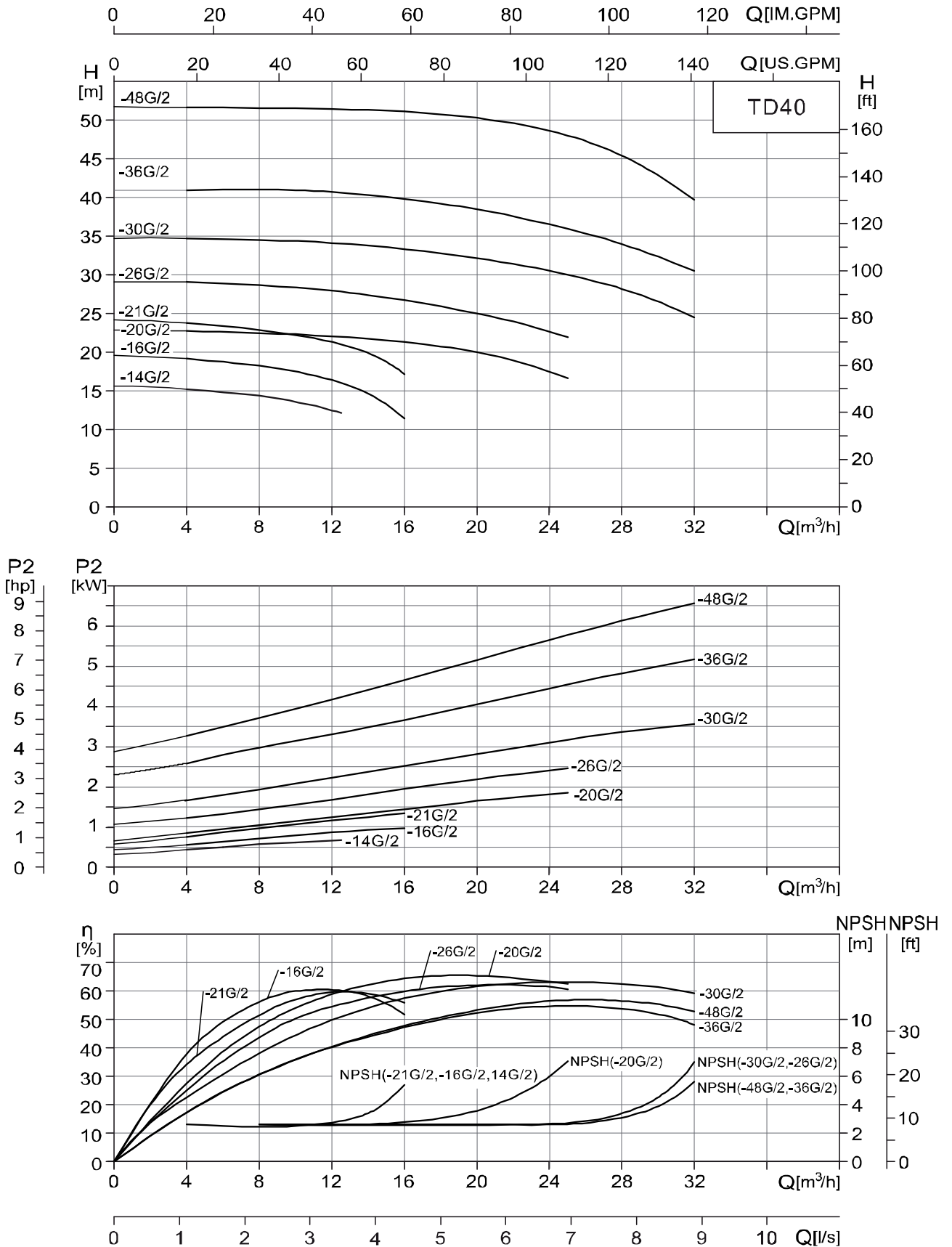

TD40 Performance table

50Hz

Model	Motor (kW)	Q (m³/h)	4	8	12.5	16	20	25	28	32
TD40-14G/2	0.75	H (m)	15.4	14	10.2					
TD40-16G/2	1.1		19.1	18.2	16	11.4				
TD40-21G/2	1.5		23.8	22.9	21	17.1				
TD40-20G/2	2.2		22.7	22.5	22	21.3	20	16.6		
TD40-26G/2	3		29	28.6	27.8	26.7	25	21.9		
TD40-30G/2	4		34.7	34.5	34.1	33.4	32.2	30	28.2	24.5
TD40-36G/2	5.5		40.9	41	40.7	39.8	38.5	36	34.1	30.5
TD40-48G/2	7.5		51.6	51.6	51.4	51.1	50.3	48	45.4	39.6

Installation sketch

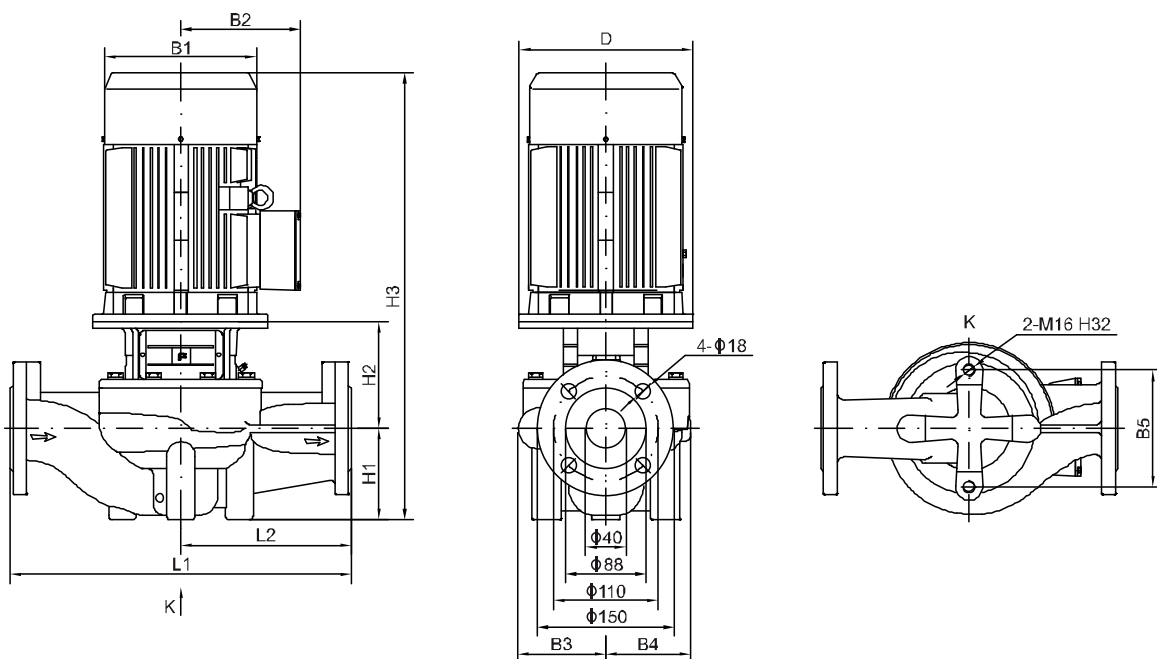

Dimensions and weights

Model	Dimension(mm)											Weight (kg)
	D	B1	B2	B3	B4	B5	H1	H2	H3	L1	L2	
TD40-14G/2	122	151	125	98	95	120	68	139	451	320	160	31
TD40-16G/2	122	151	125	98	95	120	68	139	451	320	160	32
TD40-21G/2	140	171	137	98	95	120	68	149	504	320	160	38
TD40-20G/2	140	171	137	105	95	144	85	144	516	320	160	43
TD40-26G/2	160	196	150	116	109	144	85	156	578	340	170	54
TD40-30G/2	160	214	169	116	109	144	85	156	583	340	170	62
TD40-36G/2	200	257	190	133	128	144	90	181	654	380	190	85
TD40-48G/2	200	257	190	133	128	144	90	181	654	380	190	94

Note: The dimension of single-phase motor and explosion-proof motor will change. Please consult our company for more details.

Performance curve

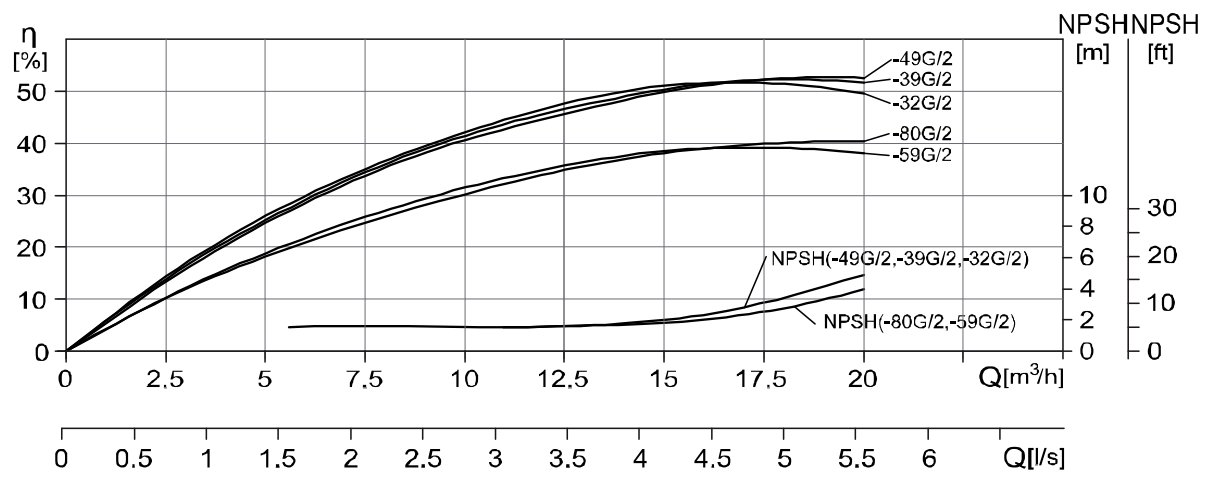
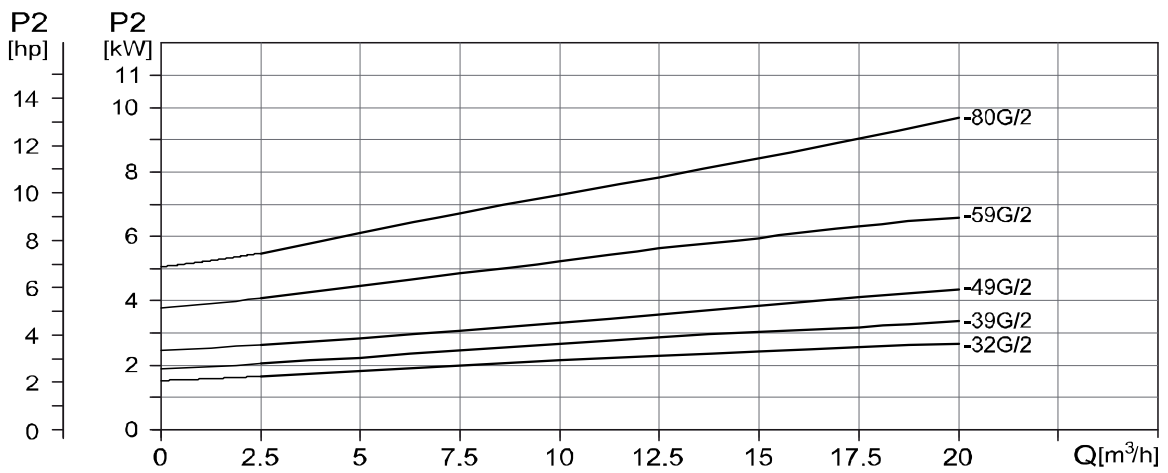
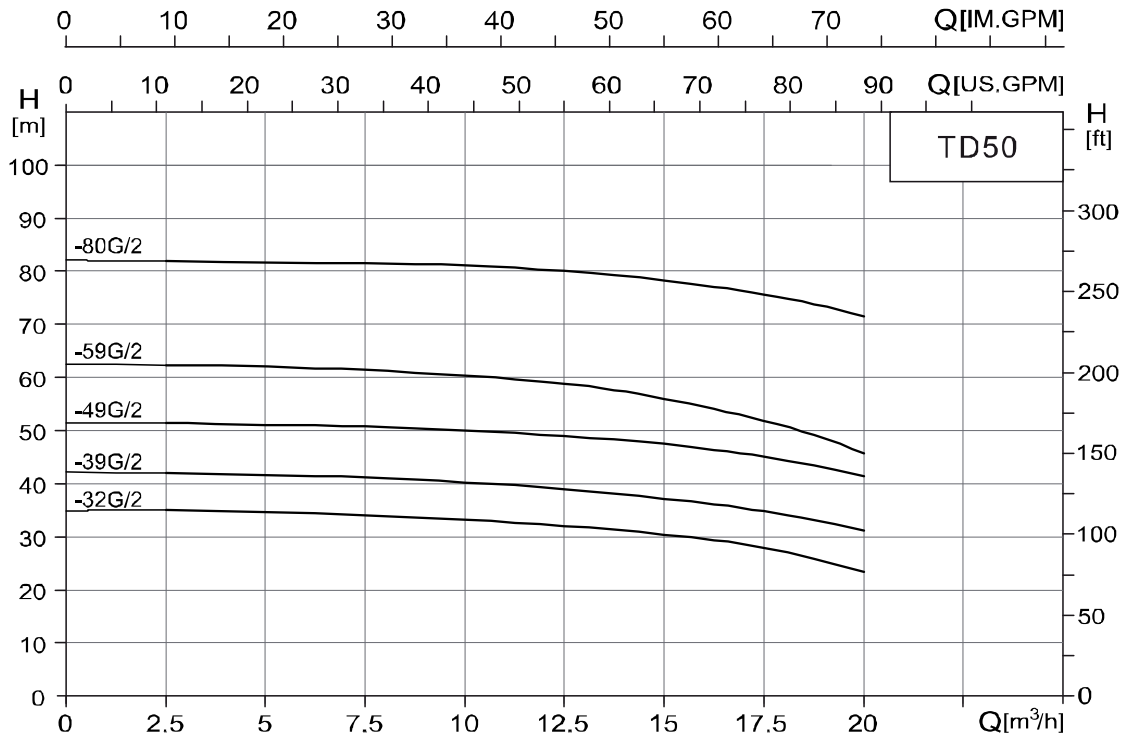

TD50 Performance table

50Hz

Model	Motor (kW)	Q (m³/h)	2.5	5	7.5	10	12.5	15	17.5	20
TD50-32G/2	3	H (m)	35	34.6	34	33.2	33	30.5	27.9	23.3
TD50-39G/2	4		41.9	41.7	41.3	40.2	39	37.2	34.8	31.2
TD50-49G/2	5.5		51.6	51.2	50.7	50	49	47.5	45.1	41.5
TD50-59G/2	7.5		62.4	62.1	61.4	60.3	59	56.1	51.9	45.7
TD50-80G/2	11		81.9	81.7	81.5	81.1	80	78.3	75.7	71.6

Installation sketch

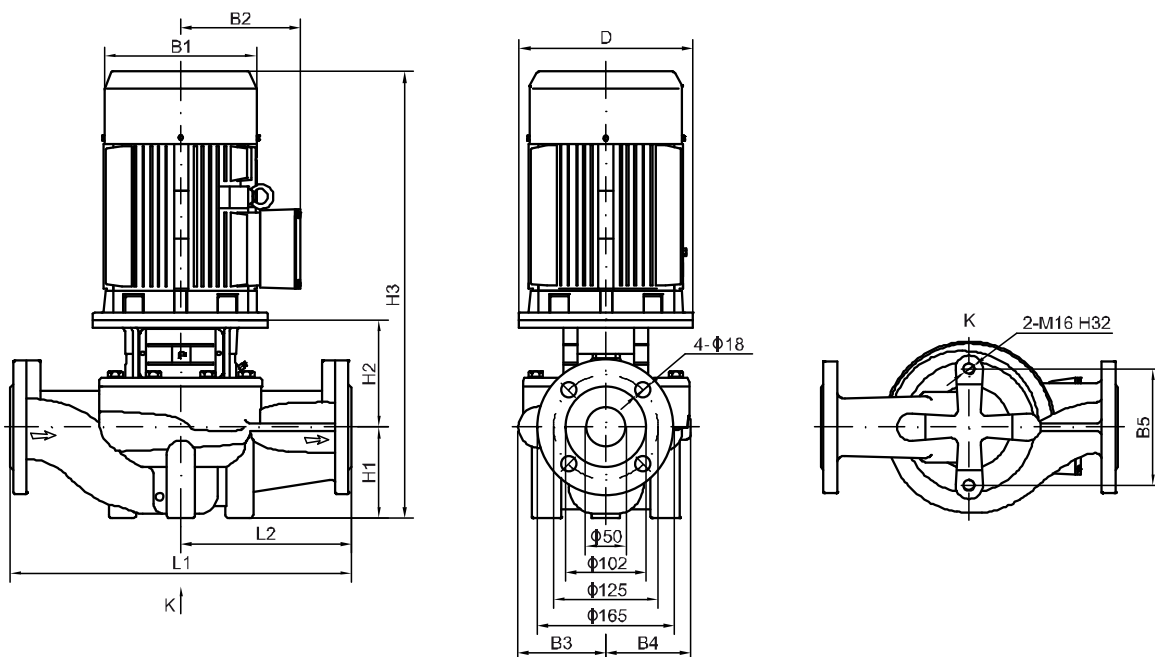

Dimensions and weights

Model	Dimension(mm)											Weight (kg)
	D	B1	B2	B3	B4	B5	H1	H2	H3	L1	L2	
TD50-32G/2	160	196	150	128	128	144	105	150	592	400	200	64
TD50-39G/2	160	214	169	128	128	144	105	150	597	400	200	71
TD50-49G/2	200	257	190	128	128	144	105	172	660	400	200	88
TD50-59G/2	200	257	190	163	163	144	105	178	666	440	220	112
TD50-80G/2	350	314	261	163	163	144	105	222	827	440	220	184

Note: The dimension of single-phase motor and explosion-proof motor will change. Please consult our company for more details.

Performance curve

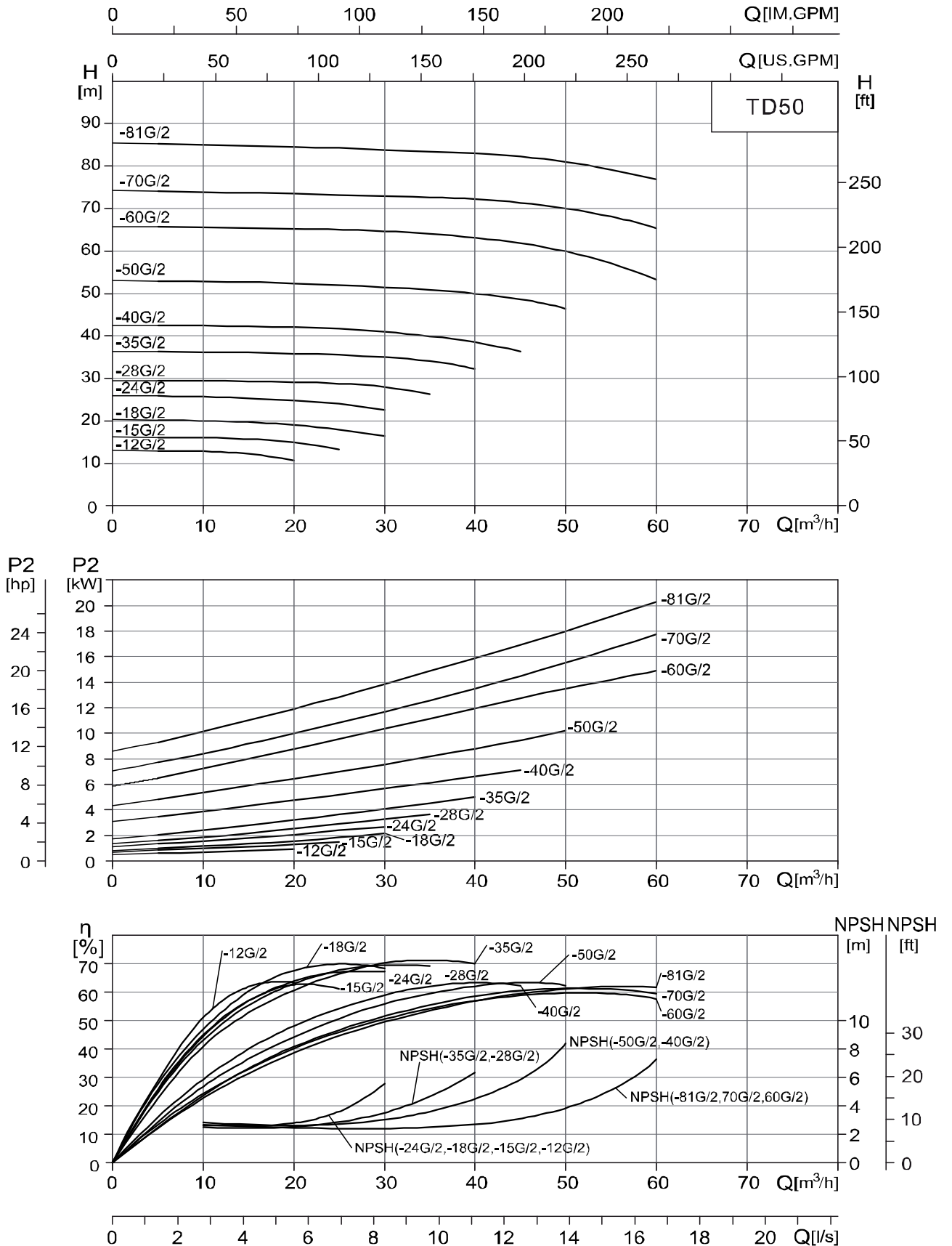

TD50 Performance table

50Hz

Model	Motor (kW)	Q (m³/h)	5	10	16	20	25	30	35	40	45	50	60
TD50-12G/2	1.1	H (m)	13	12.9	12	10.7							
TD50-15G/2	1.5		16.1	16.1	15.6	15	13.3						
TD50-18G/2	2.2		20.2	20	19.6	19	18	16.4					
TD50-24G/2	3		25.9	25.7	25.2	24.8	24	22.6					
TD50-28G/2	4		29.5	29.5	29.3	29.2	28.8	28	26.4				
TD50-35G/2	5.5		36.3	36.2	36	35.9	35.5	35	34.1	32.2			
TD50-40G/2	7.5		42.5	42.4	42.2	42.1	41.7	41	40	38.5	36.4		
TD50-50G/2	11		53	52.9	52.6	52.4	52	51.5	50.9	50	48.7	48.4	
TD50-60G/2	15		65.8	65.7	65.7	65.6	65.3	64.7	63.9	62.8	61.6	60	53.2
TD50-70G/2	18.5		73.7	73.6	73.4	73.3	73.1	72.9	72.5	72	71.2	70	65.4
TD50-81G/2	22		85.5	85.3	85	84.8	84.5	84	83.5	82.8	82.1	81	77.1

Installation sketch

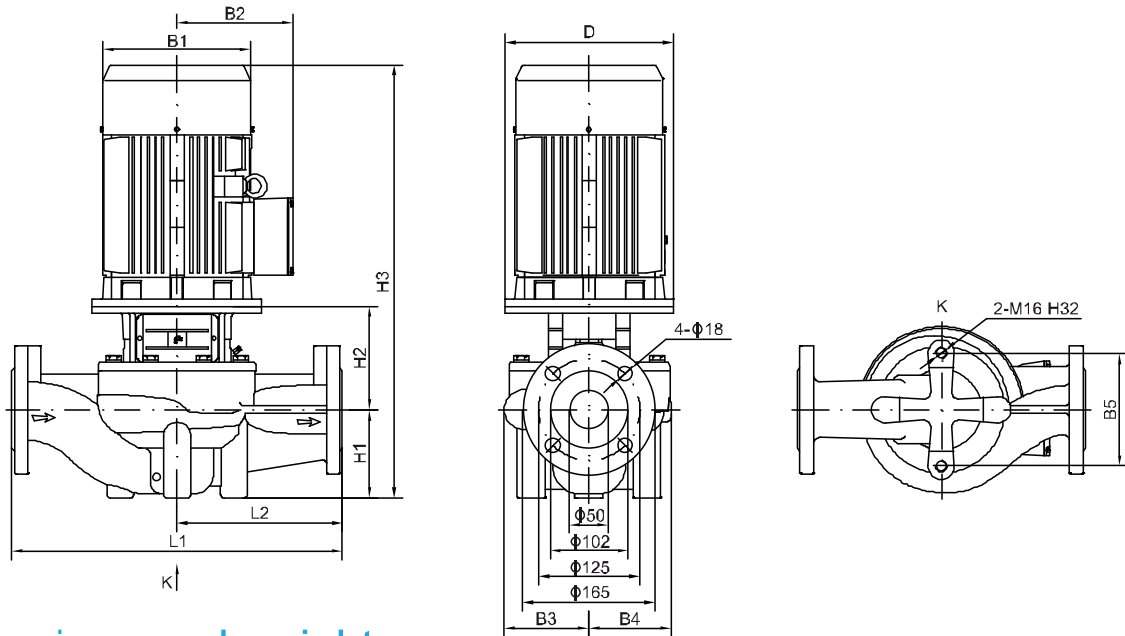

Dimensions and weights

Model	Dimension(mm)											Weight (kg)
	D	B1	B2	B3	B4	B5	H1	H2	H3	L1	L2	
TD50-12G/2	120	151	125	114	101	144	105	135	484	340	170	37
TD50-15G/2	140	171	137	114	101	144	105	137	529	340	170	42
TD50-18G/2	140	171	137	114	101	144	105	137	529	340	170	45
TD50-24G/2	160	196	150	114	101	144	105	147	589	340	170	55
TD50-28G/2	160	214	169	118	109	144	105	152	599	340	170	64
TD50-35G/2	200	257	190	118	109	144	105	176	664	340	170	81
TD50-40G/2	200	257	190	142	138	144	105	175	663	400	200	98
TD50-50G/2	350	314	261	142	138	144	105	225	830	400	200	173
TD50-60G/2	350	314	261	171	163	144	115	225	840	440	220	196
TD50-70G/2	350	314	261	171	163	144	115	225	884	440	220	203
TD50-81G/2	350	355	273	171	163	144	115	225	917	440	220	256

Note: The dimension of single-phase motor and explosion-proof motor will change. Please consult our company for more details.

Performance curve

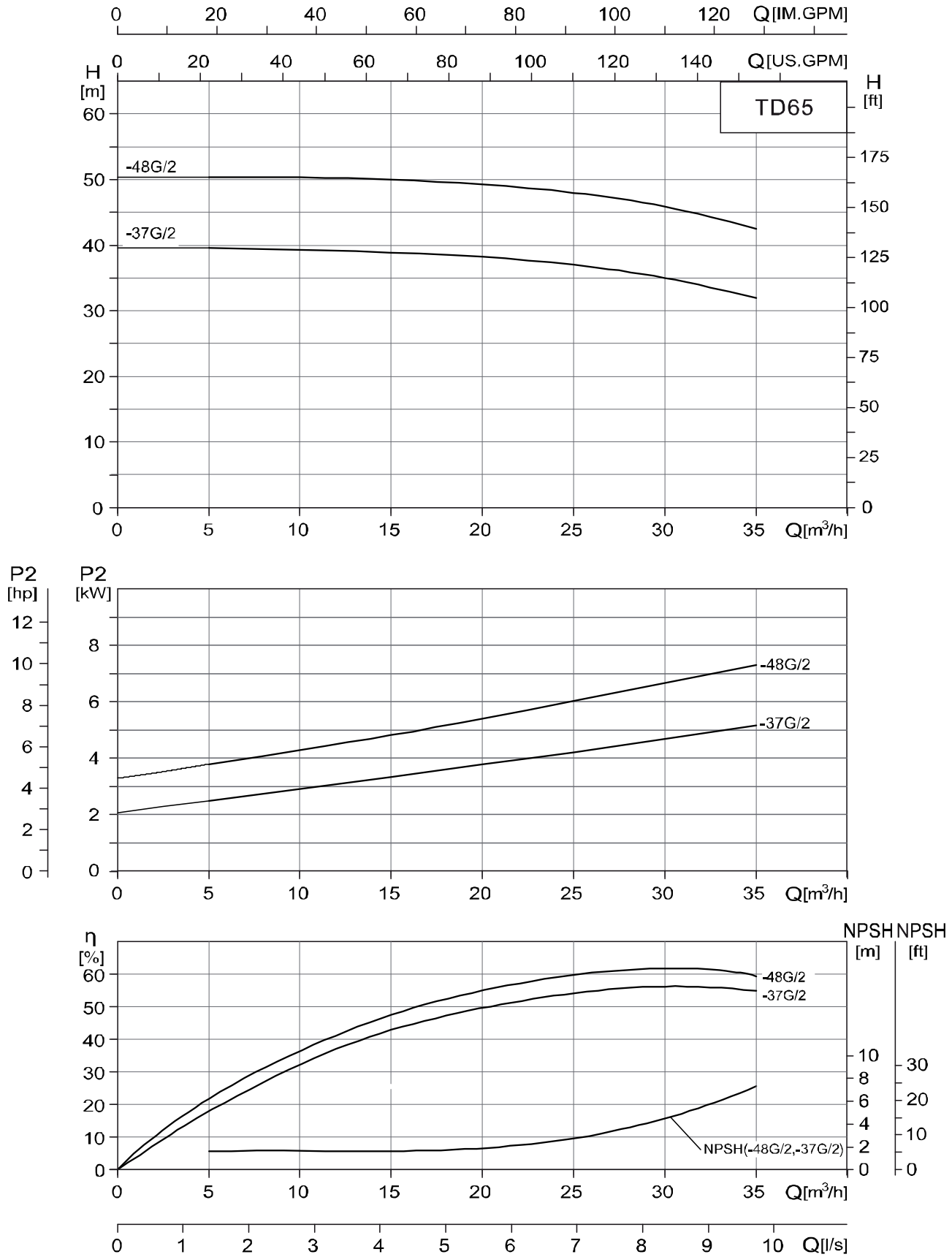

TD65 Performance table

50Hz

Model	Motor (kW)	Q (m³/h)	5	10	15	20	25	30	35
TD65-37G/2	5.5	H	39.6	39.3	39	38.2	37	35	32.1
TD65-48G/2	7.5	(m)	50.4	50.3	50	49.3	48	45.9	42.6

Installation sketch

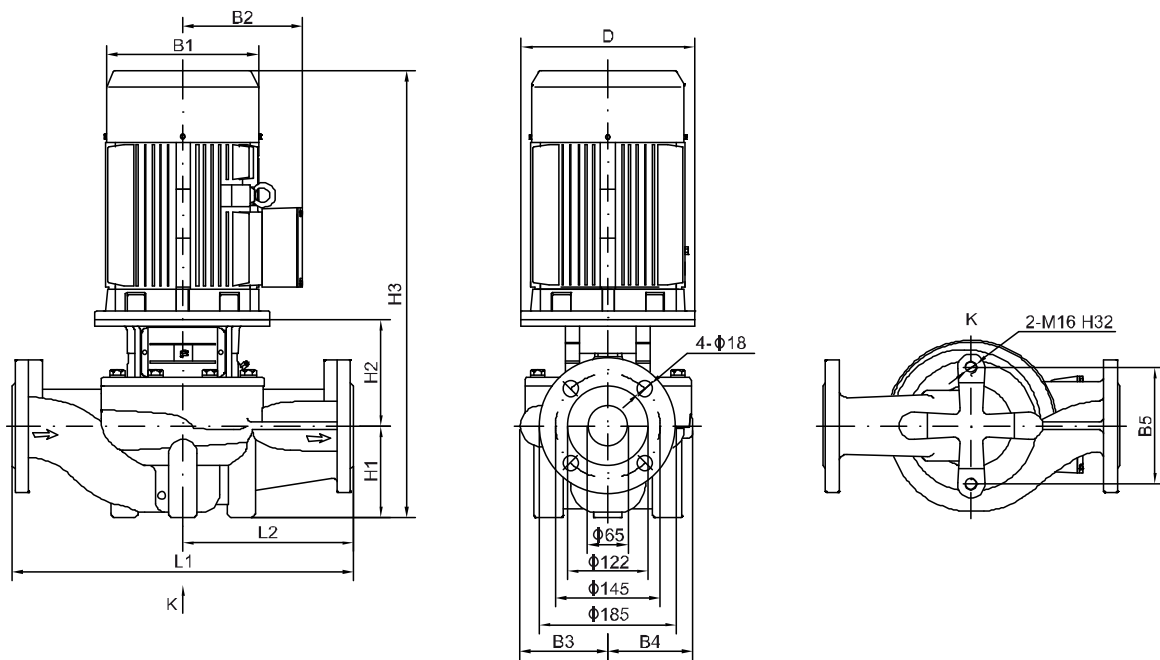

Dimensions and weights

Model	Dimension(mm)											Weight (kg)
	D	B1	B2	B3	B4	B5	H1	H2	H3	L1	L2	
TD65-37G/2	200	257	190	128	128	144	105	180	668	400	200	90
TD65-48G/2	200	257	190	128	128	144	105	180	668	400	200	98

Note: The dimension of single-phase motor and explosion-proof motor will change. Please consult our company for more details.

Performance curve

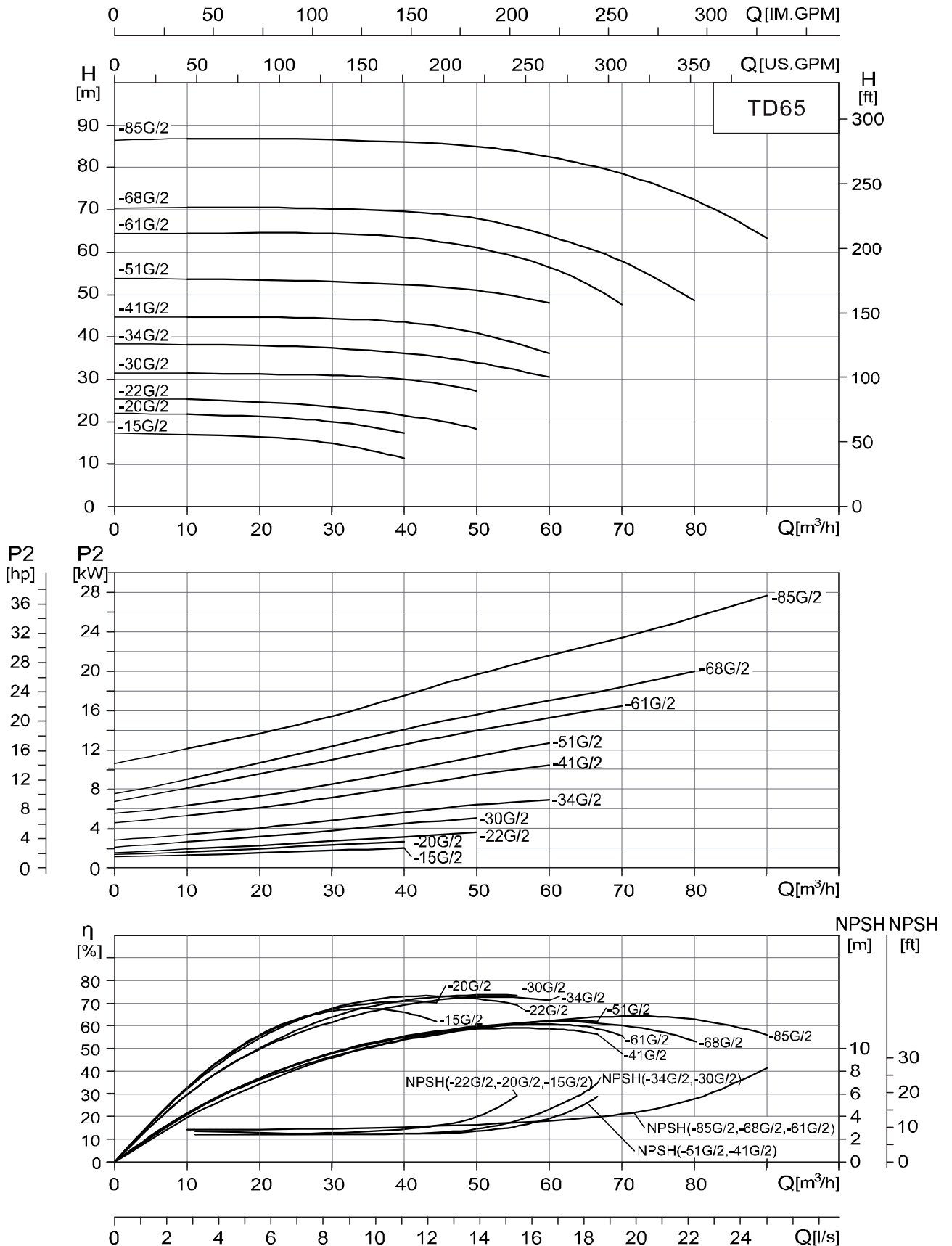

TD65 Performance table

50Hz

Model	Motor (kW)	Q (m³/h)	10	20	30	40	50	60	70	80	90
TD65-15G/2	2.2	H (m)	17.1	16.4	15	11.3					
TD65-20G/2	3		21.8	21.2	20	17.4					
TD65-22G/2	4		25.1	24.8	23.9	22	18.4				
TD65-30G/2	5.5		31.5	31.3	31	30	27.3				
TD65-34G/2	7.5		38.3	38	37.4	36.1	34	30.5			
TD65-41G/2	11		44.8	44.7	44.4	43.5	41	36.1			
TD65-51G/2	15		53.7	53.5	53.1	52.4	51	48			
TD65-61G/2	18.5		64.5	64.6	64.4	63.5	61	56.5	47.6		
TD65-68G/2	22		70.5	70.5	70.3	69.6	68	63.8	58	48.6	
TD65-85G/2	30		86.7	86.7	86.5	86	85	82.5	78.5	72.4	63.3

Installation sketch

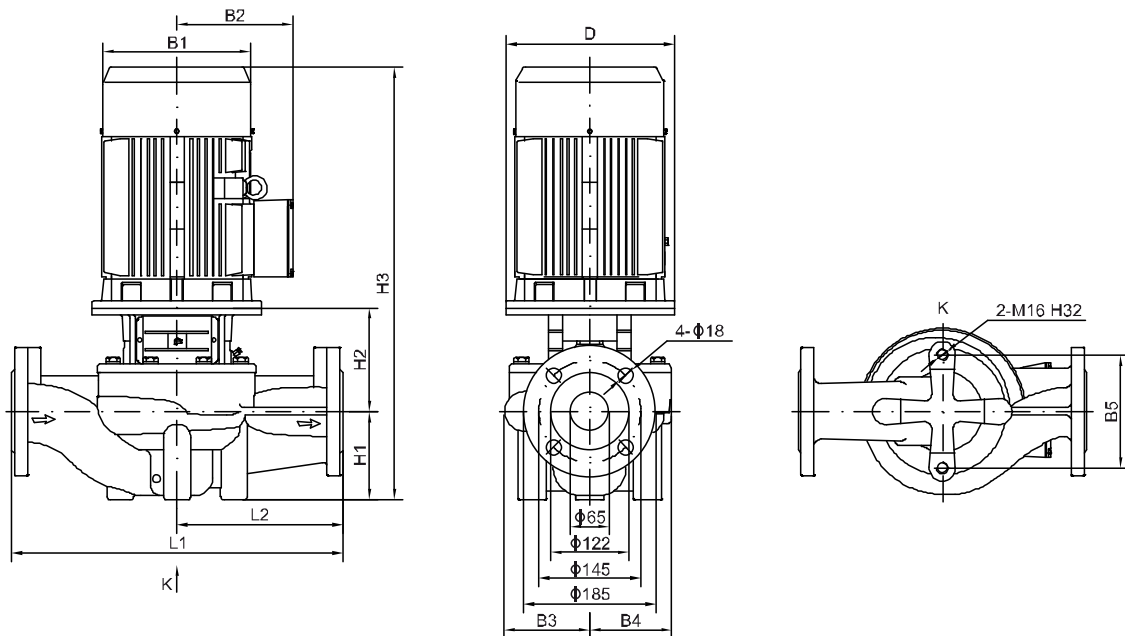

Dimensions and weights

Model	Dimension(mm)											Weight (kg)
	D	B1	B2	B3	B4	B5	H1	H2	H3	L1	L2	
TD65-15G/2	140	171	137	116	101	144	105	153	545	340	170	48
TD65-20G/2	160	196	150	116	101	144	105	163	605	340	170	57
TD65-22G/2	160	214	169	116	101	144	105	163	610	340	170	64
TD65-30G/2	200	257	190	131	115	144	105	194	682	360	180	85
TD65-34G/2	200	257	190	131	115	144	105	194	682	360	180	94
TD65-41G/2	350	314	261	148	138	144	105	234	839	400	200	173
TD65-51G/2	350	314	261	148	138	144	105	234	839	400	200	188
TD65-61G/2	350	314	261	174	162	160	125	228	897	475	238	208
TD65-68G/2	350	355	273	174	162	160	125	228	930	475	238	260
TD65-85G/2	400	397	314	174	162	160	125	231	1008	475	238	322

Note: The dimension of single-phase motor and explosion-proof motor will change. Please consult our company for more details.

Performance curve

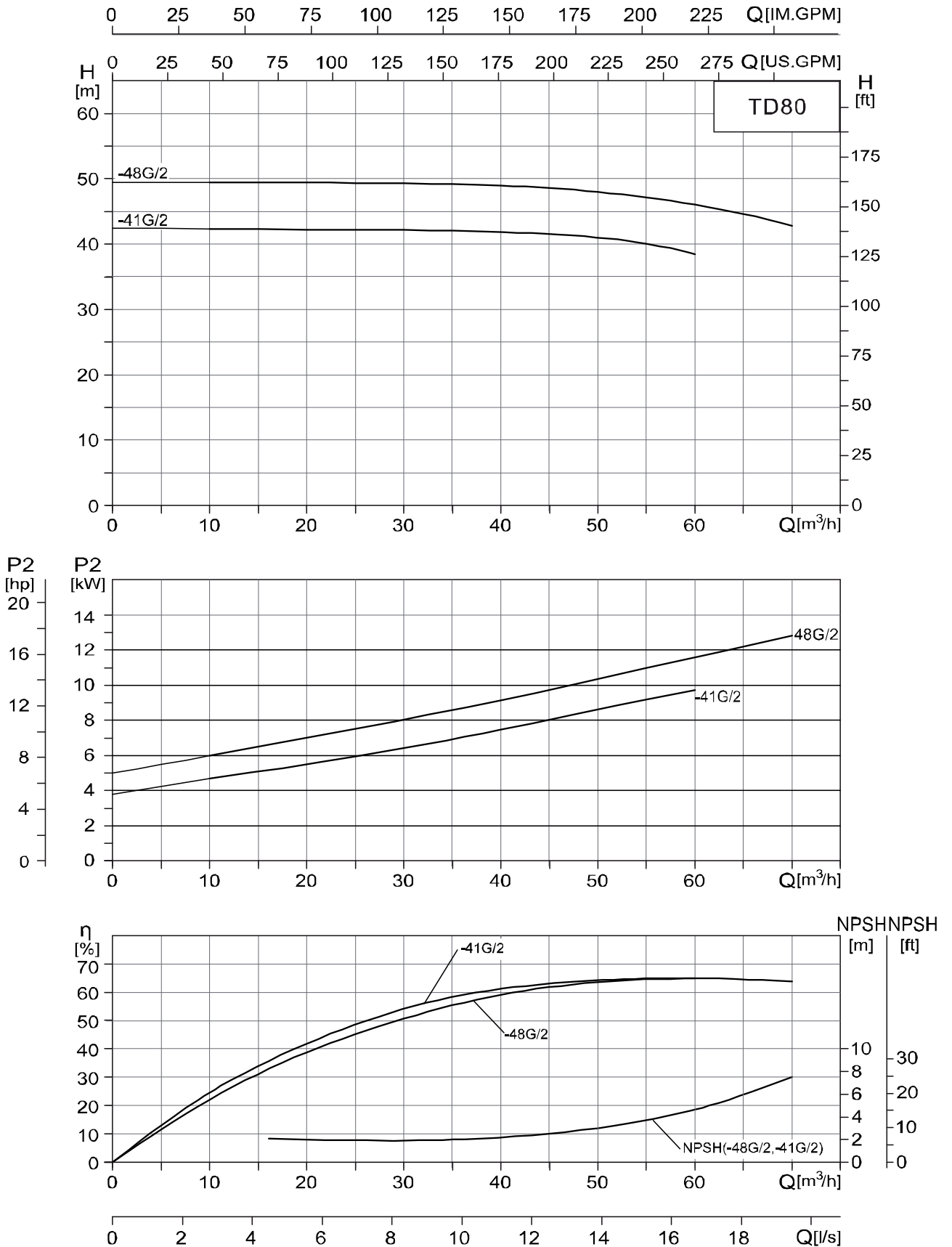

TD80 Performance table

50Hz

Model	Motor (kW)	Q (m ³ /h)	10	20	30	40	50	60	70
TD80-41G/2	11	H	42.3	42.2	42.1	41.8	41	38.4	
TD80-48G/2	15	(m)	49.4	49.4	49.3	49	48	46	42.8

Installation sketch

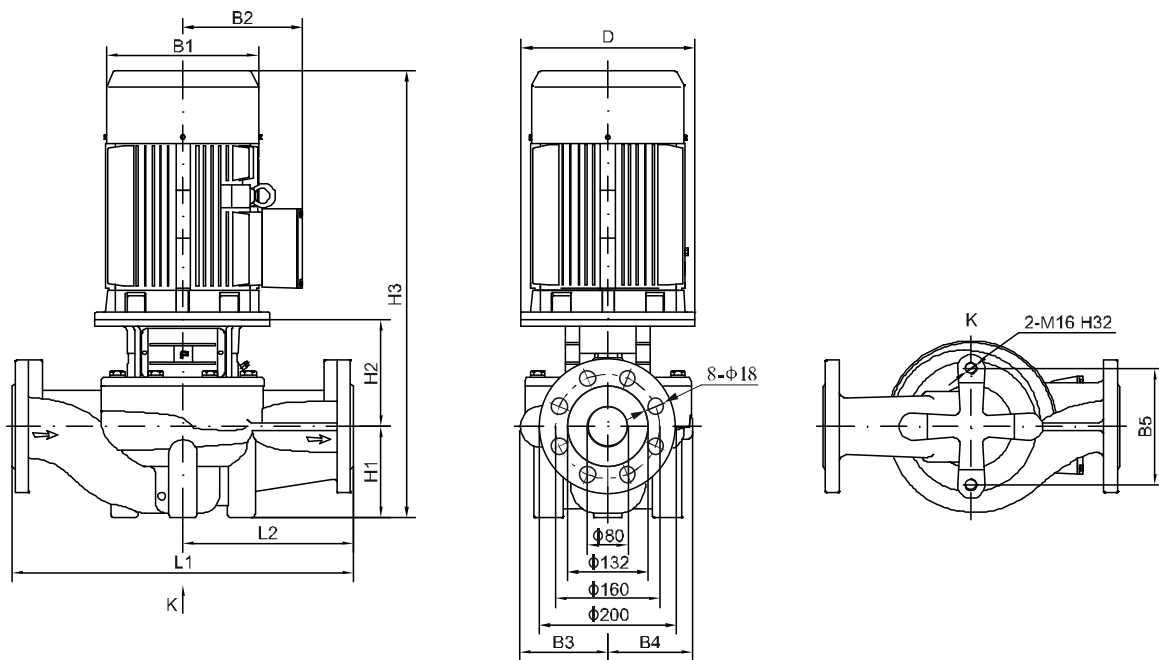

Dimensions and weights

Model	Dimension(mm)											Weight (kg)
	D	B1	B2	B3	B4	B5	H1	H2	H3	L1	L2	
TD80-41G/2	350	314	261	137	128	144	115	221	836	500	250	176
TD80-48G/2	350	314	261	137	128	144	115	221	836	500	250	191

Note: The dimension of single-phase motor and explosion-proof motor will change. Please consult our company for more details.

Performance curve

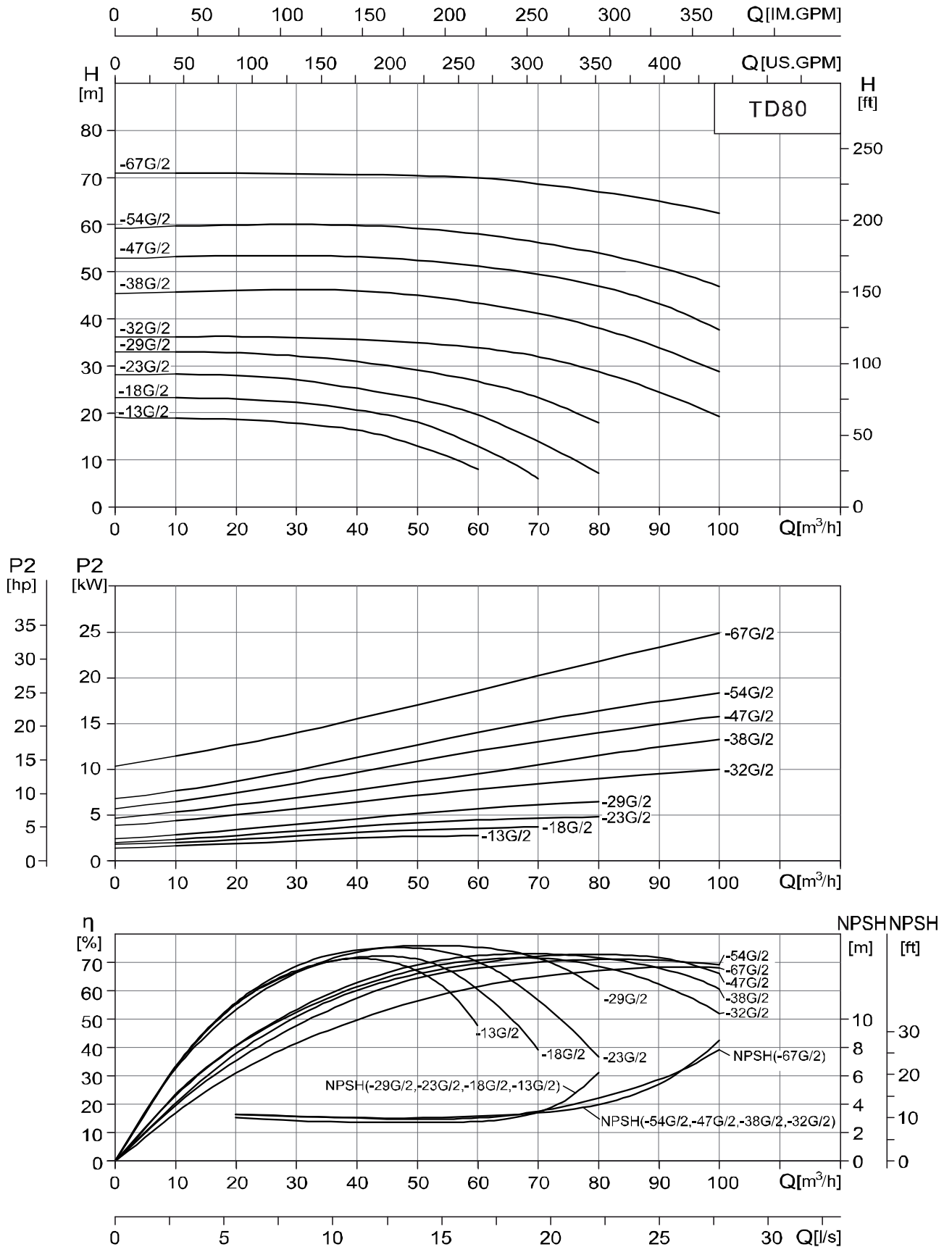

TD80 Performance table

50Hz

Model	Motor (kW)	Q (m³/h)	10	20	30	40	50	60	70	80	90	100
TD80-13G/2	3	H (m)	18.9	18.6	17.8	16.3	13	8				
TD80-18G/2	4		23.2	23	22.2	20.6	18	12.9	6			
TD80-23G/2	5.5		28.2	28	27	25.2	23	19.5	13.9	7.1		
TD80-29G/2	7.5		33	32.8	32.1	30.9	29	26.7	23.2	17.8		
TD80-32G/2	11		36.2	36.2	36	35.6	34.9	33.8	32	28.7	24.4	19.3
TD80-38G/2	15		45.7	45.9	46.2	45.9	45	43.3	41.1	38	33.8	28.8
TD80-47G/2	18.5		53.2	53.4	53.4	53.2	52.4	51.2	49.4	47	43.2	37.6
TD80-54G/2	22		59.7	59.9	60	59.8	59.2	58	56.2	54	50.9	46.9
TD80-67G/2	30		71	70.9	70.8	70.6	70.4	69.9	68.7	67	65	62.3

Installation sketch

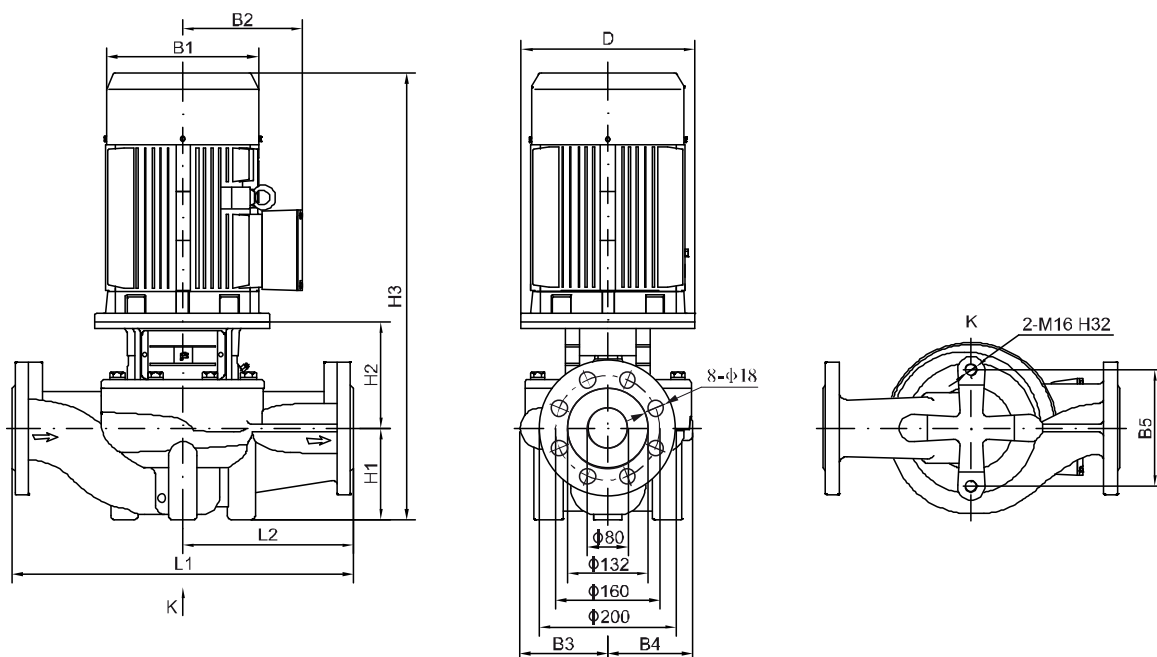

Dimensions and weights

Model	Dimension(mm)											Weight (kg)
	D	B1	B2	B3	B4	B5	H1	H2	H3	L1	L2	
TD80-13G/2	160	196	150	134	112	144	105	171	613	400	200	63
TD80-18G/2	160	214	169	134	112	144	105	171	618	400	200	70
TD80-23G/2	200	257	190	134	112	144	105	195	683	400	200	87
TD80-29G/2	200	257	190	134	112	144	105	195	683	400	200	95
TD80-32G/2	350	314	261	159	138	144	115	240	855	450	225	179
TD80-38G/2	350	314	261	159	138	144	115	240	855	450	225	194
TD80-47G/2	350	314	261	159	138	144	115	240	899	450	225	203
TD80-54G/2	350	355	273	159	138	144	115	240	932	450	225	256
TD80-67G/2	400	397	314	180	162	160	115	242	1009	500	250	324

Note: The dimension of single-phase motor and explosion-proof motor will change. Please consult our company for more details.

Performance curve

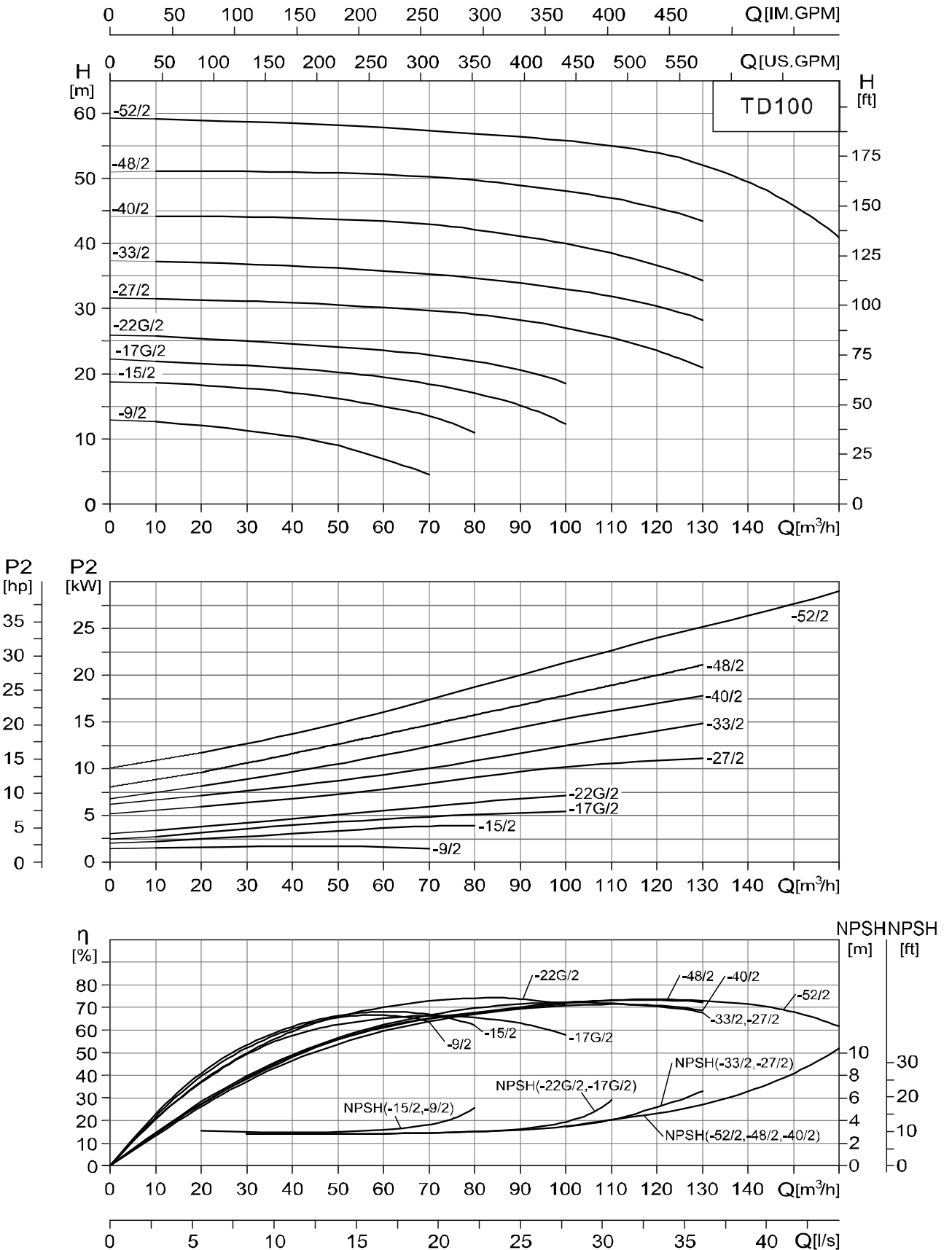

TD100 Performance table

50Hz

Model	Motor (kW)	Q (m³/h)	H (m)															
			10	20	30	40	50	60	70	80	90	100	110	120	130	145	160	
TD100-9/2	2.2		13.9	13.2	12.2	10.8	9	6.8	4.4									
TD100-15/2	4		18.6	18.2	17.7	17.1	16.2	15	13.4	11								
TD100-17G/2	5.5		21.9	21.6	21.2	20.8	20	19.4	18.4	17	15.1	12.3						
TD100-22G/2	7.5		25.7	25.5	25	24.6	24.1	23.6	22.9	21.9	20.5	18.6						
TD100-27/2	11		31.5	31.3	31.1	30.9	30.7	30.3	29.8	29.2	28.2	27	25.5	23.6	20.8			
TD100-33/2	15		37.1	37	36.8	36.6	36.2	35.8	35.3	34.7	33.9	33	31.7	30.1	27.9			
TD100-40G/2	18.5		44.1	44.1	44	43.9	43.7	43.4	42.9	42.1	41.1	40	38.5	36.6	34.3			
TD100-48G/2	22		51.2	51.1	51	51	50.8	50.6	50.2	49.7	48.9	48	47.0	45.5	43.5			
TD100-52G/2	30		59.1	58.9	58.7	58.4	58.2	57.8	57.3	56.9	56.4	55.8	55	53.9	52	47.7	40.8	

Installation sketch

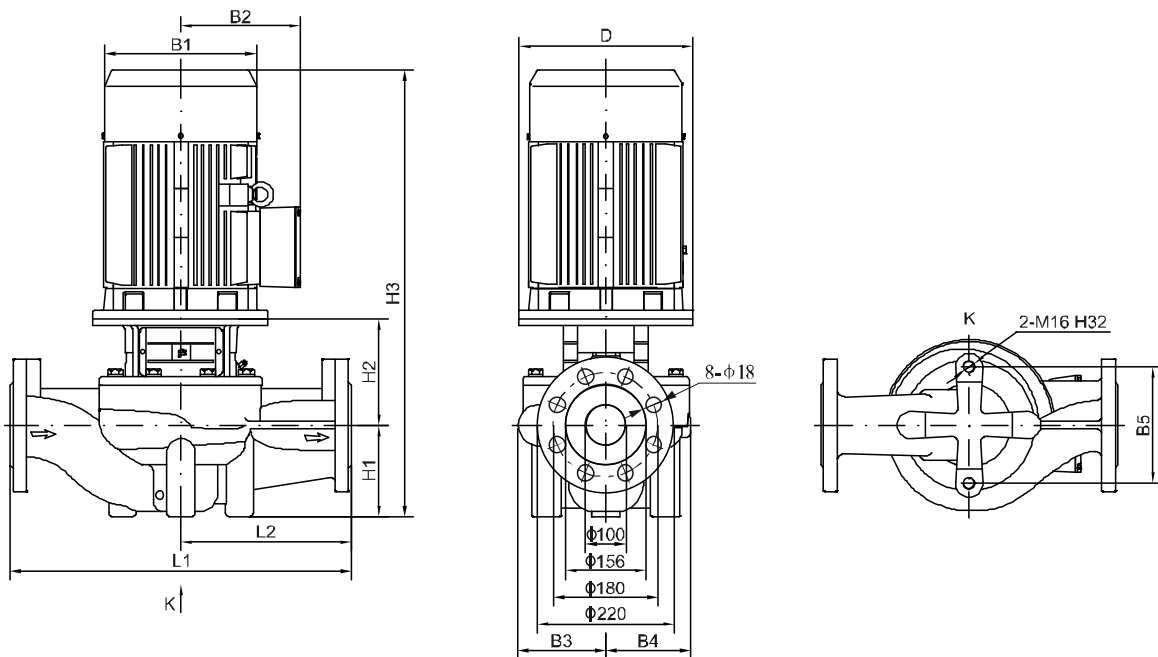

Dimensions and weights

Model	Dimension(mm)											Weight (kg)
	D	B1	B2	B3	B4	B5	H1	H2	H3	L1	L2	
TD100-9/2	140	171	137	134	101	160	107	172	566	450	225	56
TD100-15/2	160	214	169	134	101	160	107	190	639	450	225	73
TD100-17G/2	200	257	190	146	118	144	120	199	702	450	225	96
TD100-22G/2	200	257	190	146	118	144	120	199	702	450	225	104
TD100-27/2	350	314	261	147	123	144	140	260	900	550	275	187
TD100-33/2	350	314	261	147	123	144	140	260	900	550	275	202
TD100-40G/2	350	314	261	181	152	230	140	257	941	550	275	220
TD100-48G/2	350	355	273	181	152	230	140	257	974	550	275	273
TD100-52G/2	400	397	314	181	152	230	140	257	1049	550	275	336

Note: The dimension of single-phase motor and explosion-proof motor will change. Please consult our company for more details.

Performance curve

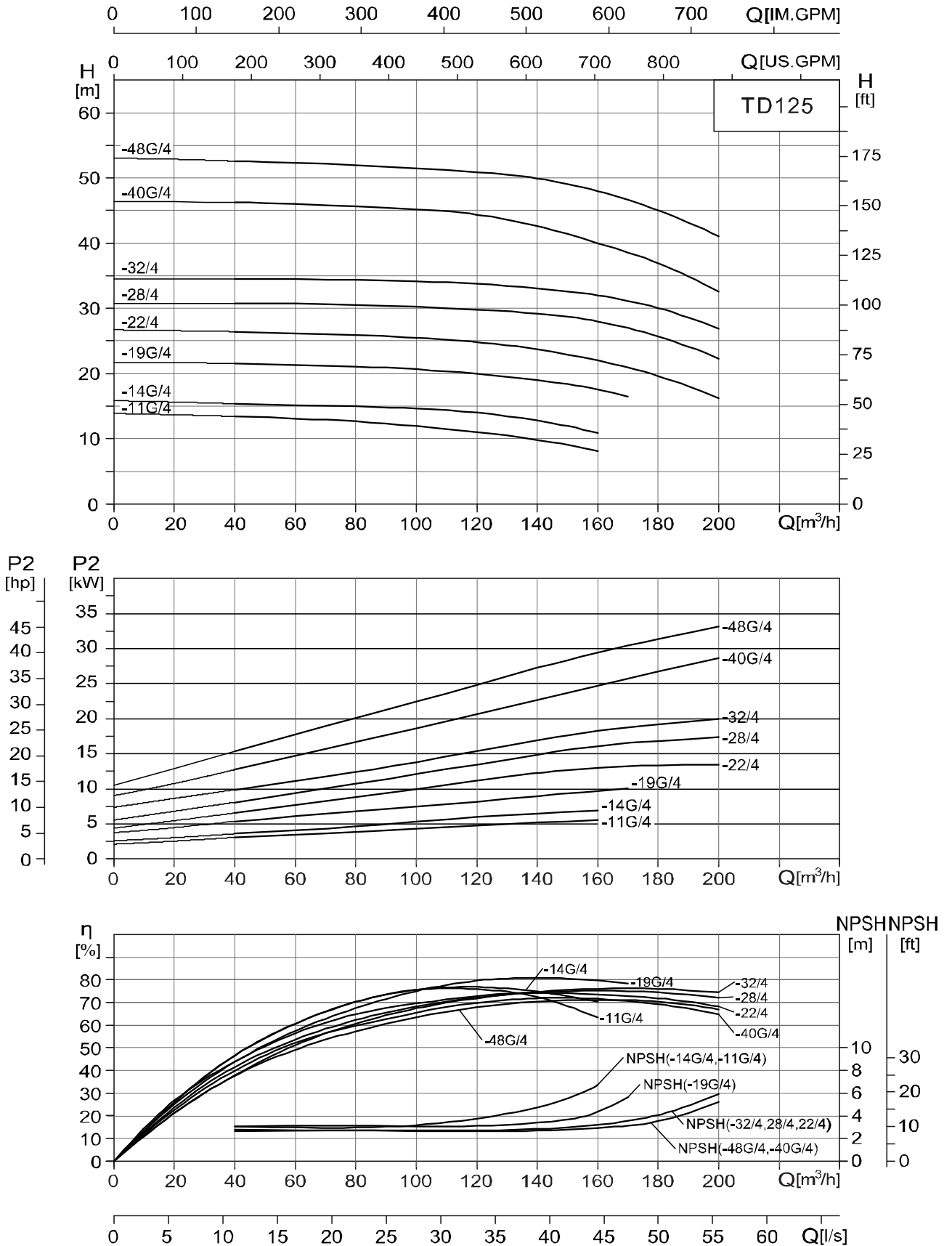

TD125 Performance table

50Hz

Model	Motor (kW)	Q (m³/h)	40	60	80	100	120	140	160	170	180	200
TD125-11G/4	5.5	H (m)	13.4	13.1	12.6	11.9	11	9.8	8.1			
TD125-14G/4	7.5		15.4	15.2	15	14.7	14	12.8	10.9			
TD125-19G/4	11		21.5	21.3	21.1	20.7	19.9	19	17.6	16.5		
TD125-22G/4	15		26.7	26.5	26.2	25.7	24.9	23.7	22	20.9	19.8	16.7
TD125-28G/4	18.5		30.9	30.8	30.7	30.5	30.1	29.3	28	26.9	25.8	22.2
TD125-32G/4	22		34.6	34.6	34.5	34.4	34	33.3	32	31.1	30.2	27.3
TD125-40G/4	30		46.2	46	45.7	45.2	44.3	42.5	40	38.5	36.9	32.5
TD125-48G/4	37		52.6	52.3	51.9	51.5	50.9	49.9	48	46.6	45	41.1

Installation sketch

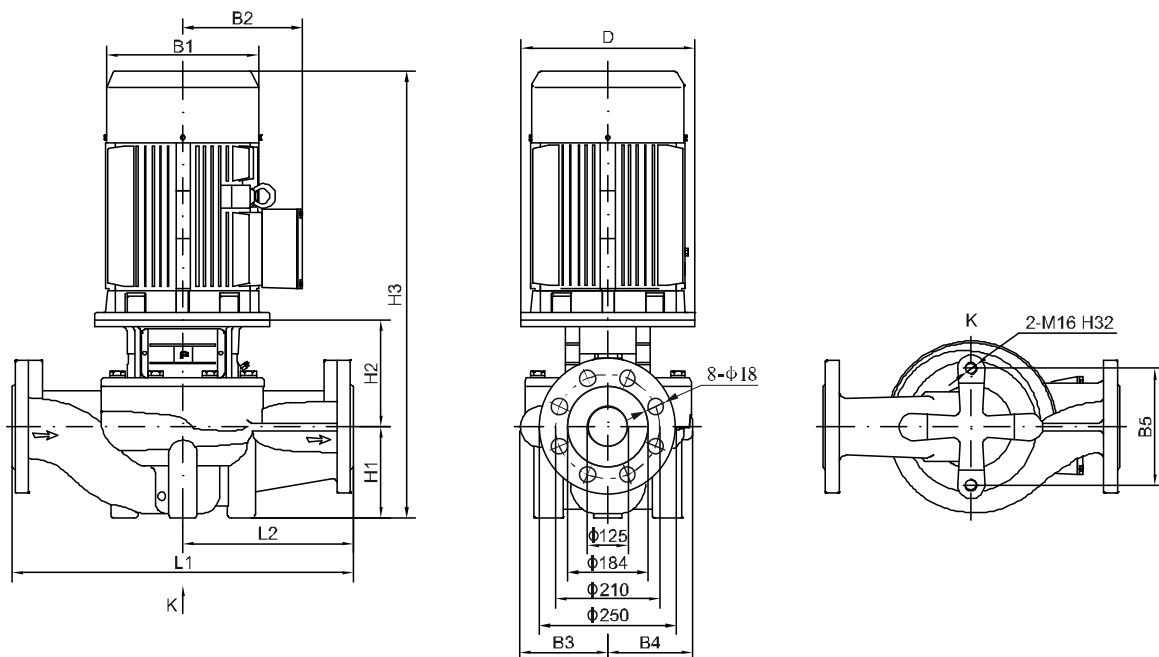

Dimensions and weights

Model	Dimension(mm)											Weight (kg)
	D	B1	B2	B3	B4	B5	H1	H2	H3	L1	L2	
TD125-11G/4	200	257	190	198	162	230	160	229	772	620	310	140
TD125-14G/4	200	257	190	198	162	230	160	229	772	620	310	150
TD125-19G/4	350	314	261	213	178	230	160	301	961	660	330	255
TD125-22G/4	350	314	261	236	208	230	215	292	1051	800	400	310
TD125-28G/4	350	355	273	236	208	230	215	292	1084	800	400	340
TD125-32G/4	350	355	273	236	208	230	215	292	1122	800	400	361
TD125-40G/4	400	397	314	261	233	230	160	298	1110	800	400	455
TD125-48G/4	450	445	334	261	233	230	160	313	1147	800	400	492

Note: The dimension of single-phase motor and explosion-proof motor will change. Please consult our company for more details.

Performance curve

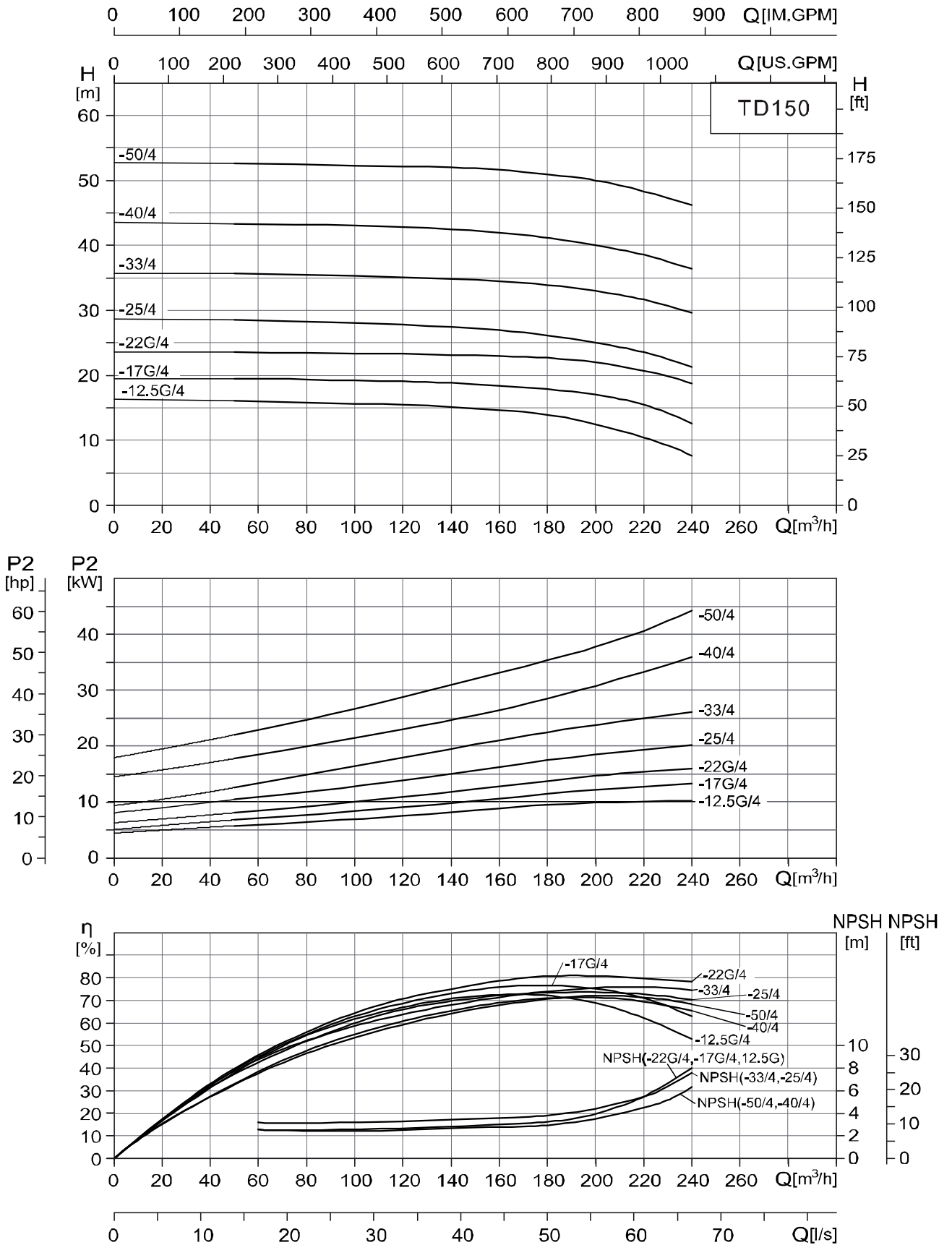

TD150 Performance table

50Hz

Model	Motor (kW)	Q (m³/h)	50	80	100	120	140	160	180	200	220	240
TD150-12.5G/4	11	H (m)	16.1	15.8	15.6	15.4	15.1	14.6	13.9	12.5	10.4	7.6
TD150-17G/4	15		19.5	19.4	19.2	19.1	18.8	18.4	17.9	17	15.5	12.6
TD150-22G/4	18.5		23.6	23.4	23.4	23.2	23.1	23	22.7	22	20.7	18.7
TD150-25/4	22		28.1	28	27.9	27.7	27.3	26.8	26.1	25	23.5	21.3
TD150-33/4	30		35.5	35.4	35.3	35.1	34.8	34.4	33.9	33	31.5	29.6
TD150-40/4	37		43.1	43	42.9	42.7	42.4	41.9	41.1	40	38.4	36.2
TD150-50/4	45		52.4	52.2	52.1	51.9	51.7	51.4	50.9	50	48.7	46.7

Installation sketch

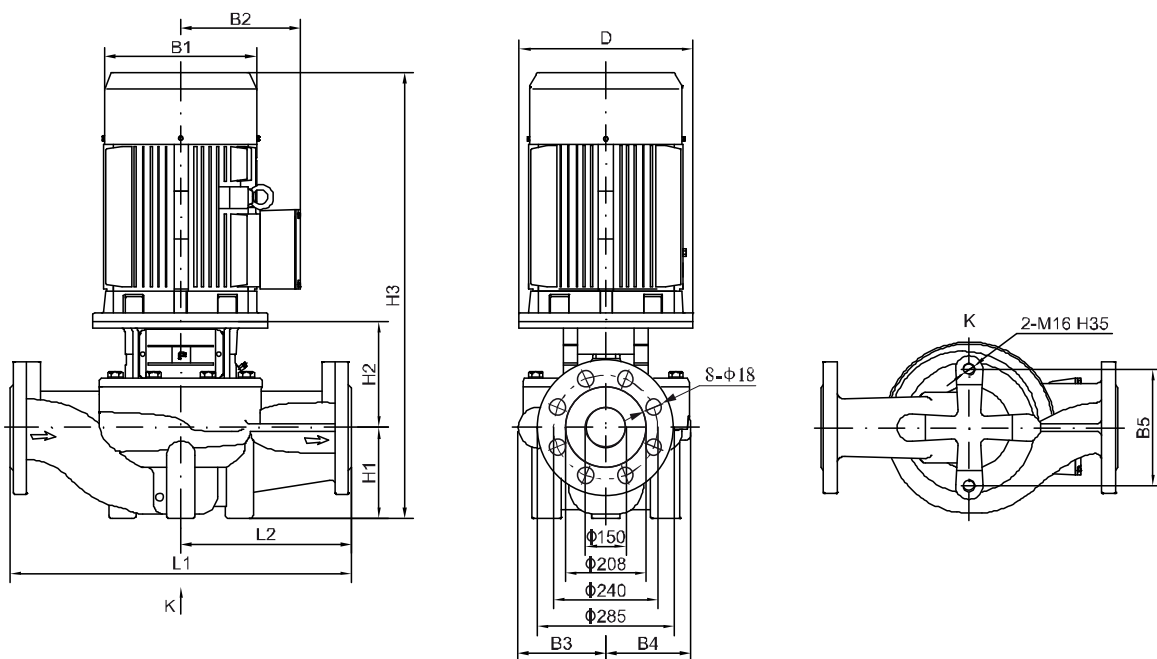

Dimensions and weights

Model	Dimension(mm)											Weight (kg)
	D	B1	B2	B3	B4	B5	H1	H2	H3	L1	L2	
TD150-12.5G/4	350	314	261	217	180	230	175	297	972	660	330	260
TD150-17G/4	350	314	261	217	180	230	175	297	1016	660	330	281
TD150-22G/4	350	355	273	217	180	230	175	297	1049	660	330	312
TD150-25/4	350	355	273	238	208	230	215	269	1099	800	400	365
TD150-33/4	400	397	314	238	208	230	215	269	1136	800	400	445
TD150-40/4	450	445	334	267	248	230	230	288	1192	900	450	518
TD150-50/4	450	445	334	267	248	230	230	288	1215	900	450	570

Note: The dimension of single-phase motor and explosion-proof motor will change. Please consult our company for more details.

Performance curve

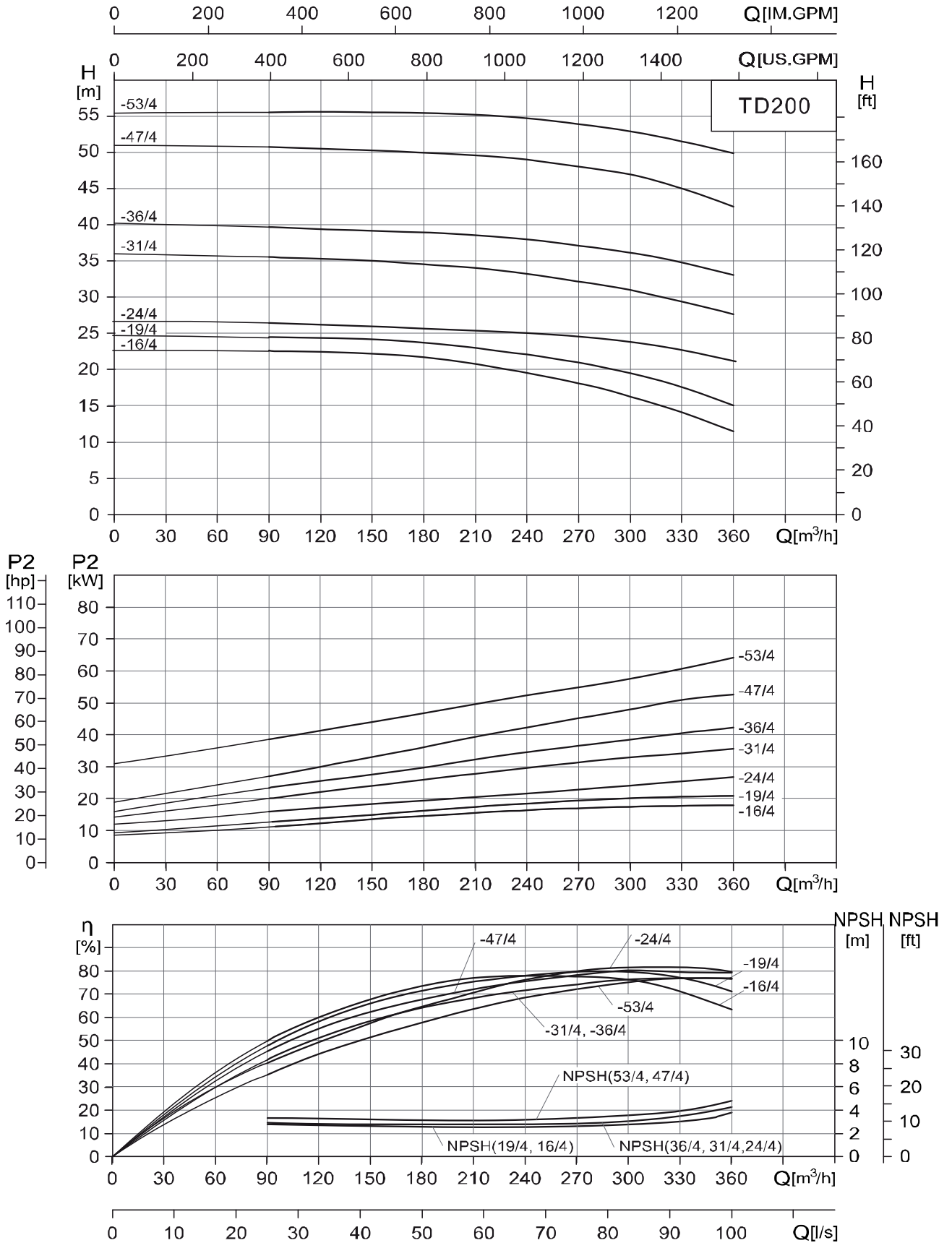

TD200 Performance table

50Hz

Model	Motor (kW)	Q (m³/h)	90	120	150	180	210	240	270	300	330	360
TD200-16/4	18.5	H (m)	22.6	22.4	22.2	21.7	20.7	19.4	18.1	16	14	11.5
TD200-19/4	22		24.4	24.3	24.2	23.7	23	22	20.9	19	17.6	15
TD200-24/4	30		26.1	26	25.8	25.7	25.4	25.1	24.6	24	23.1	21.5
TD200-31/4	37		35.4	35.3	35	34.5	33.9	33.2	32.2	31	29.3	27.6
TD200-36/4	45		39.6	39.4	39.1	38.8	38.5	37.9	37	36	34.7	33
TD200-47/4	55		50.6	50.5	50.2	49.8	49.5	48.9	48	47	44.9	42.4
TD200-53/4	75		55.7	55.7	55.7	55.5	55.3	54.8	54	53	51.6	50

Installation sketch

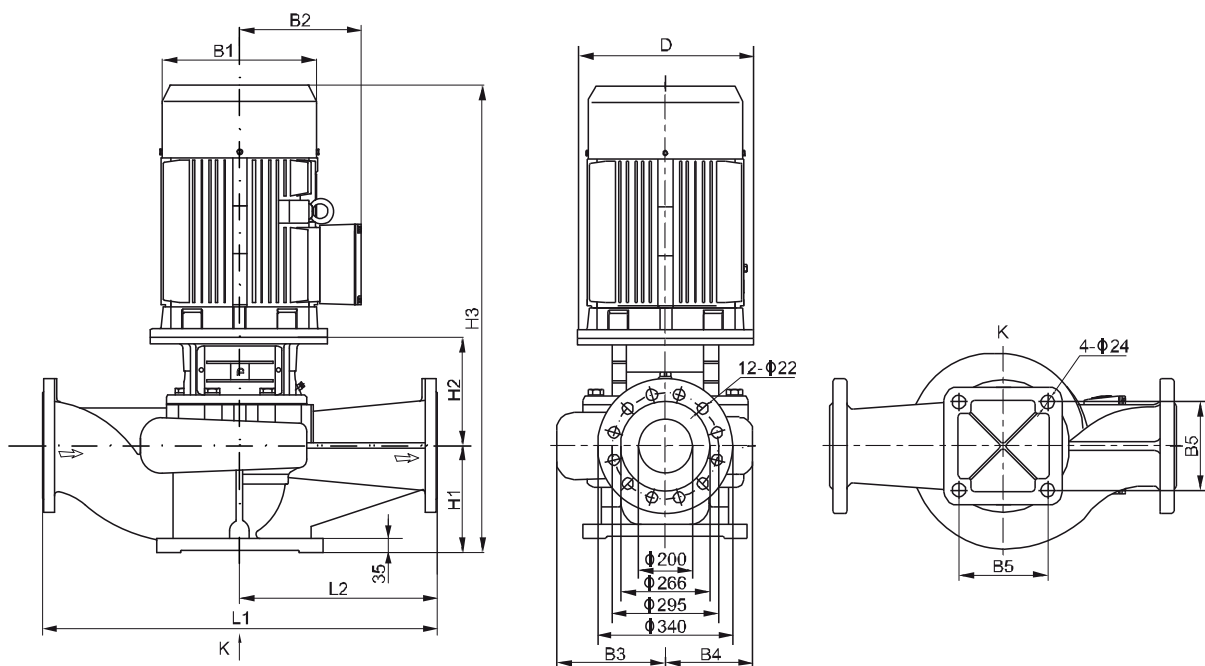

Dimensions and weights

Model	Dimension(mm)											Weight (kg)
	D	B1	B2	B3	B4	B5	H1	H2	H3	L1	L2	
TD200-16/4	350	355	273	278	219	360	270	415	1262	1000	500	417
TD200-19/4	350	355	273	278	219	360	270	415	1300	1000	500	434
TD200-24/4	400	397	314	303	252	360	270	415	1337	1100	550	537
TD200-31/4	450	445	334	303	252	360	270	445	1389	1100	550	602
TD200-36/4	450	445	334	303	252	360	270	445	1412	1100	550	648
TD200-47/4	550	484	367	315	269	360	270	457	1500	1100	550	744
TD200-53/4	550	547	407	315	269	360	270	457	1587	1100	550	877

Note: The dimension of single-phase motor and explosion-proof motor will change. Please consult our company for more details.

Performance curve

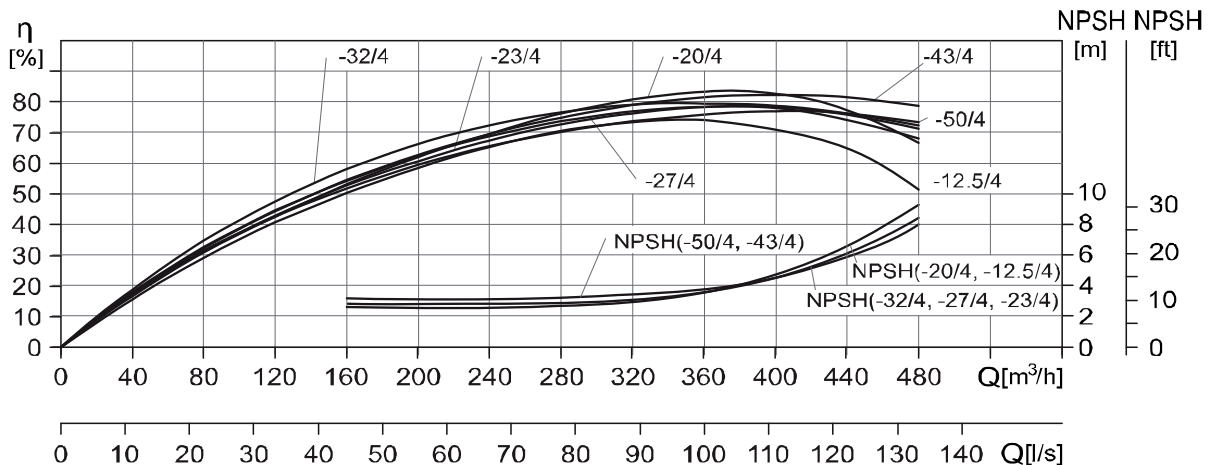
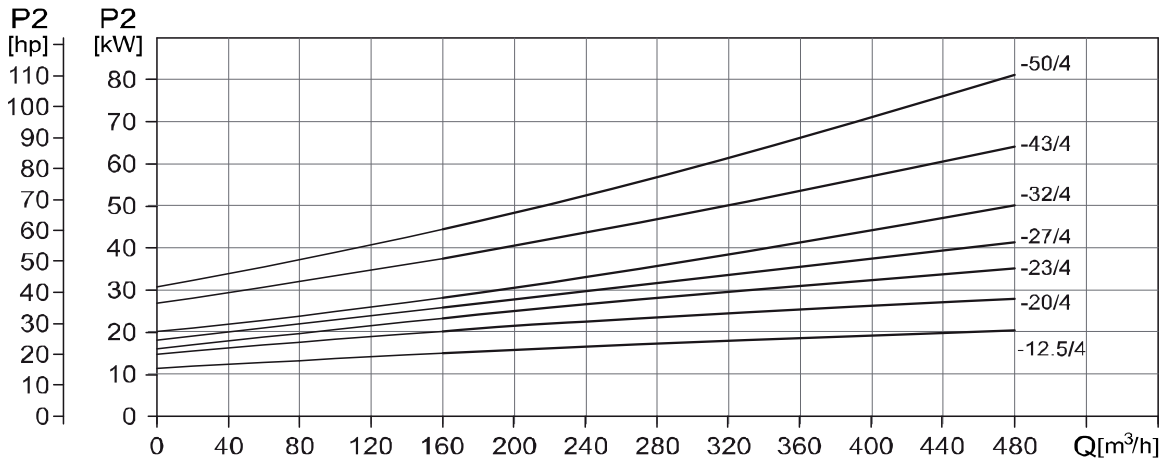
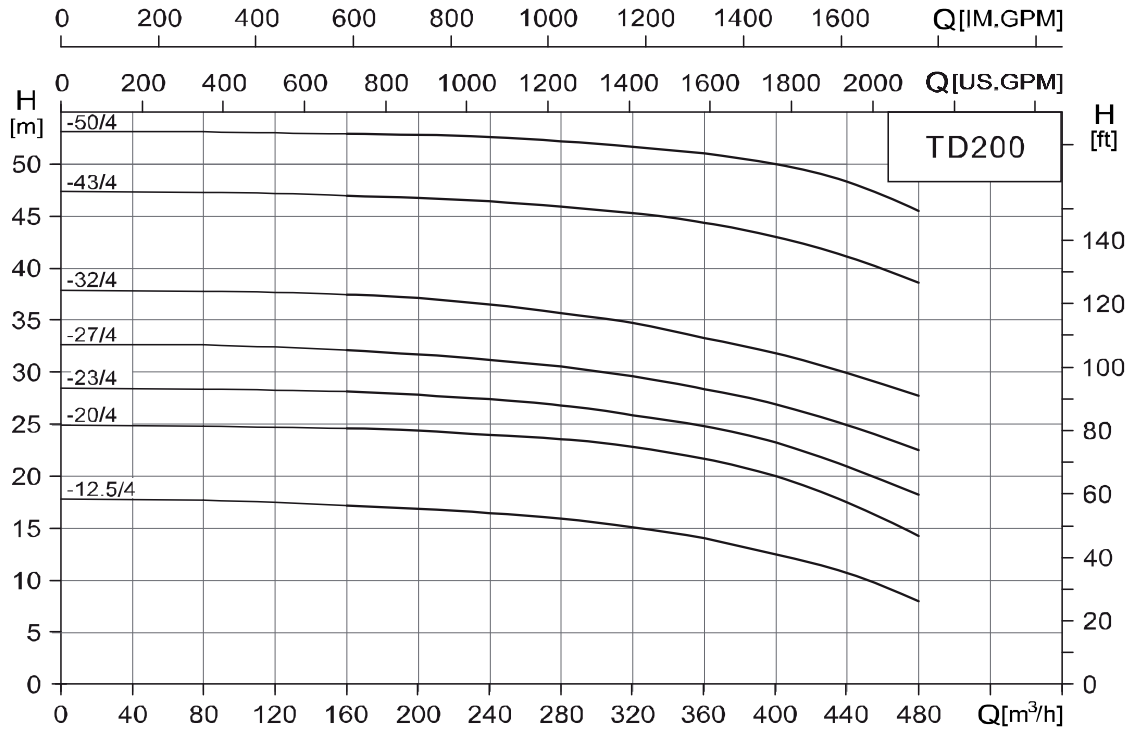

TD200 Performance table

50Hz

Model	Motor (kW)	Q (m³/h)	160	200	240	280	320	360	400	440	480
TD200-12.5/4	22	H (m)	17.2	16.9	16.5	15.9	15.1	14	12.5	10.7	8
TD200-20/4	30		24.6	24.4	24	23.6	22.8	21.7	20	17.5	14.2
TD200-23/4	37		28.1	27.8	27.4	26.8	25.9	24.8	23	20.9	18.2
TD200-27/4	45		32.1	31.7	31.2	30.5	29.6	28.4	27	24.9	22.5
TD200-32/4	55		37.5	37.1	36.5	35.7	34.7	33.3	32	29.9	27.7
TD200-43/4	75		47	46.7	46.4	45.9	45.3	44.4	43	41.1	38.6
TD200-50/4	90		52.9	52.8	52.6	52.2	51.7	51	50	48.3	45.5

Installation sketch

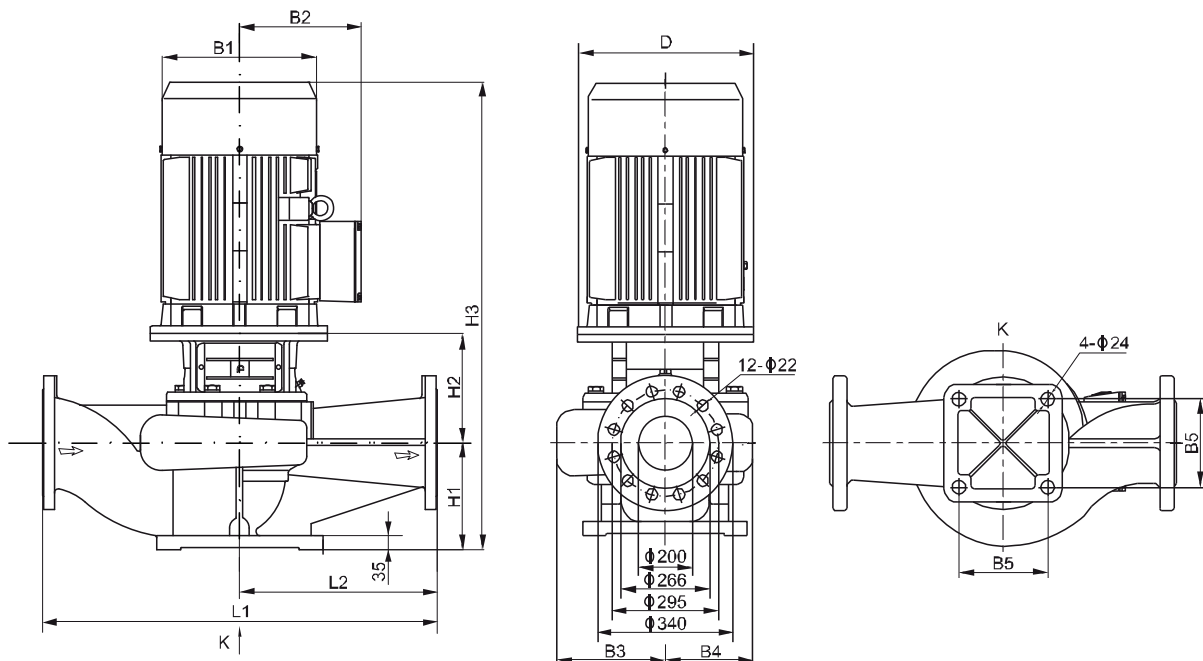

Dimensions and weights

Model	Dimension(mm)											Weight (kg)
	D	B1	B2	B3	B4	B5	H1	H2	H3	L1	L2	
TD200-12.5/4	350	355	273	278	219	360	270	415	1300	1000	500	432
TD200-20/4	400	397	314	278	219	360	270	415	1377	1000	500	492
TD200-23/4	450	445	334	303	252	360	270	445	1389	1100	550	602
TD200-27/4	450	445	334	303	252	360	270	445	1412	1100	550	638
TD200-32/4	550	484	367	303	252	360	270	445	1488	1100	550	710
TD200-43/4	550	547	407	315	269	360	270	457	1587	1100	550	883
TD200-50/4	550	547	407	315	269	360	270	457	1607	1100	550	975

Note: The dimension of single-phase motor and explosion-proof motor will change. Please consult our company for more details.

Performance curve

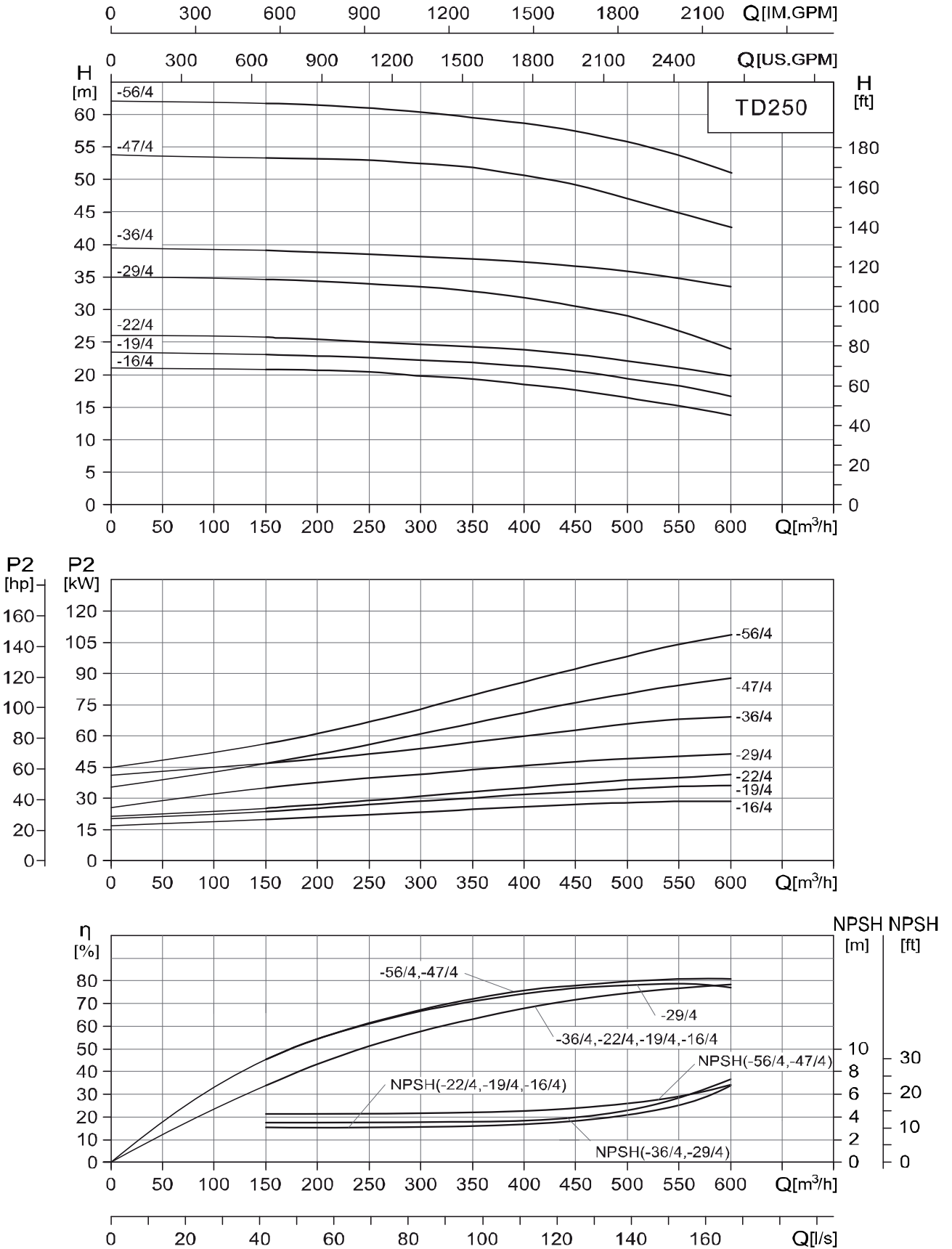

TD250 Performance table

50Hz

Model	Motor (kW)	Q (m³/h)	150	200	250	300	350	400	450	500	550	600
TD250-16/4	30	H (m)	20.5	20.4	20.1	19.6	19	18.2	17.3	16	14.7	13.3
TD250-19/4	37		22.7	22.4	22.1	21.7	21.3	20.8	20.1	19	17.9	16.6
TD250-22/4	45		25.7	25.3	25.1	24.7	24.3	23.8	23.1	22	21	19.7
TD250-29/4	55		34.6	34.4	34	34.4	32.6	31.8	30.6	29	26.8	23.9
TD250-36/4	75		39.1	38.8	38.5	38.2	37.8	37.3	36.8	36	34.3	32.5
TD250-47/4	90		53.3	53.1	52.9	52.4	51.8	50.6	49.2	47	45	42.5
TD250-56/4	110		61.6	61.4	60.9	60.2	59.5	58.6	57.4	56	53.8	51

Installation sketch

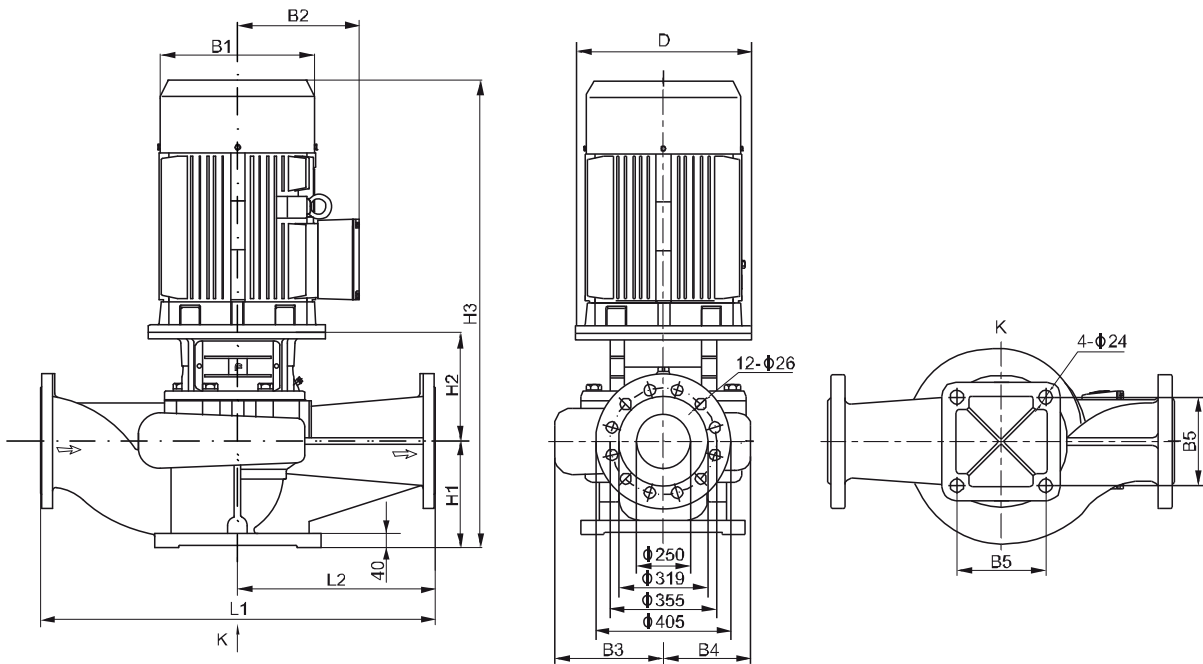

Dimensions and weights

Model	Dimension(mm)											Weight (kg)
	D	B1	B2	B3	B4	B5	H1	H2	H3	L1	L2	
TD250-16/4	400	397	314	316	243	390	300	465	1417	1100	550	550
TD250-19/4	450	445	334	316	243	390	300	495	1469	1100	550	611
TD250-22/4	450	445	334	316	243	390	300	495	1492	1100	550	647
TD250-29/4	550	484	367	329	264	440	300	507	1580	1100	550	773
TD250-36/4	550	547	407	329	264	440	300	507	1667	1100	550	909
TD250-47/4	550	547	407	347	292	440	305	485	1670	1200	600	1030
TD250-56/4	660	645	535	347	292	440	305	525	1883	1200	600	1389

Note: The dimension of single-phase motor and explosion-proof motor will change. Please consult our company for more details.

Performance curve

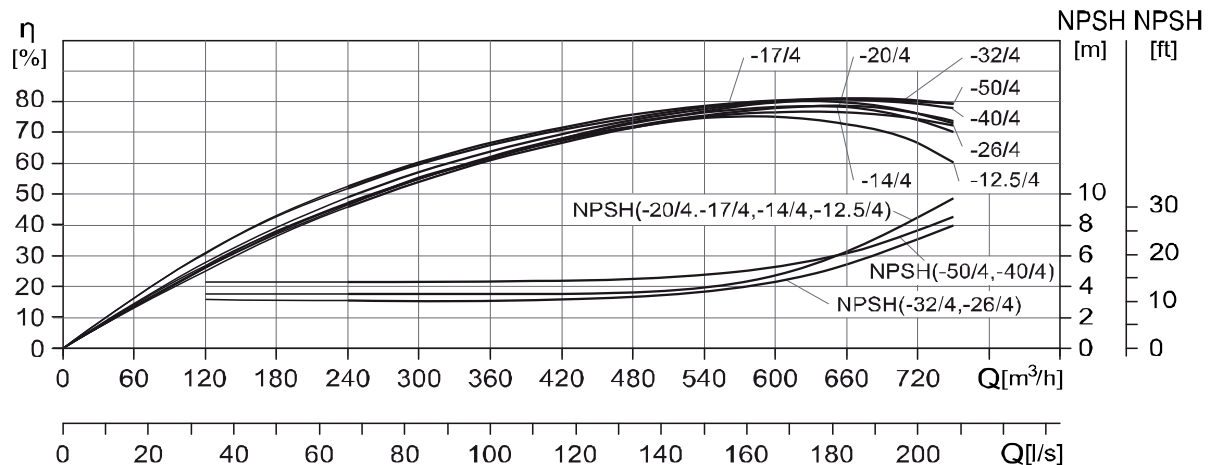
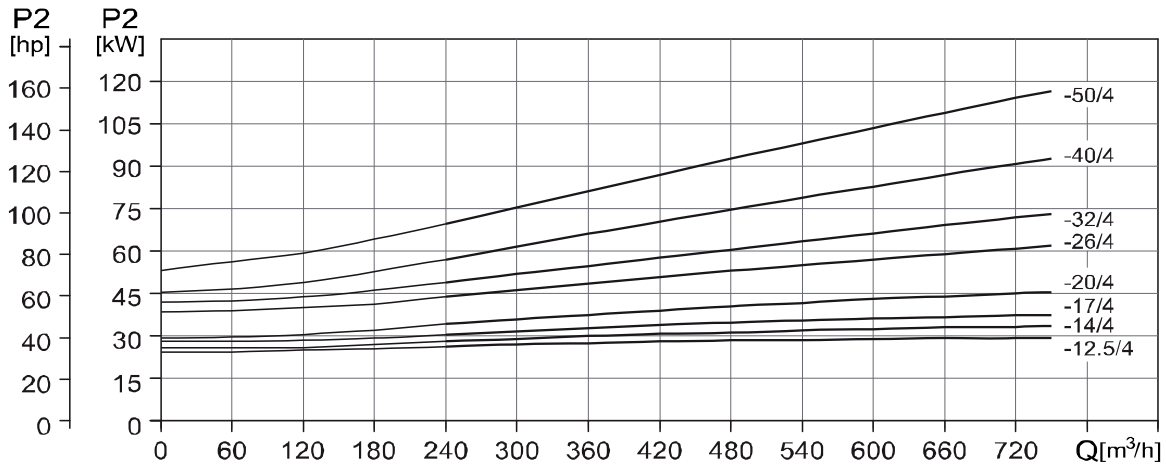
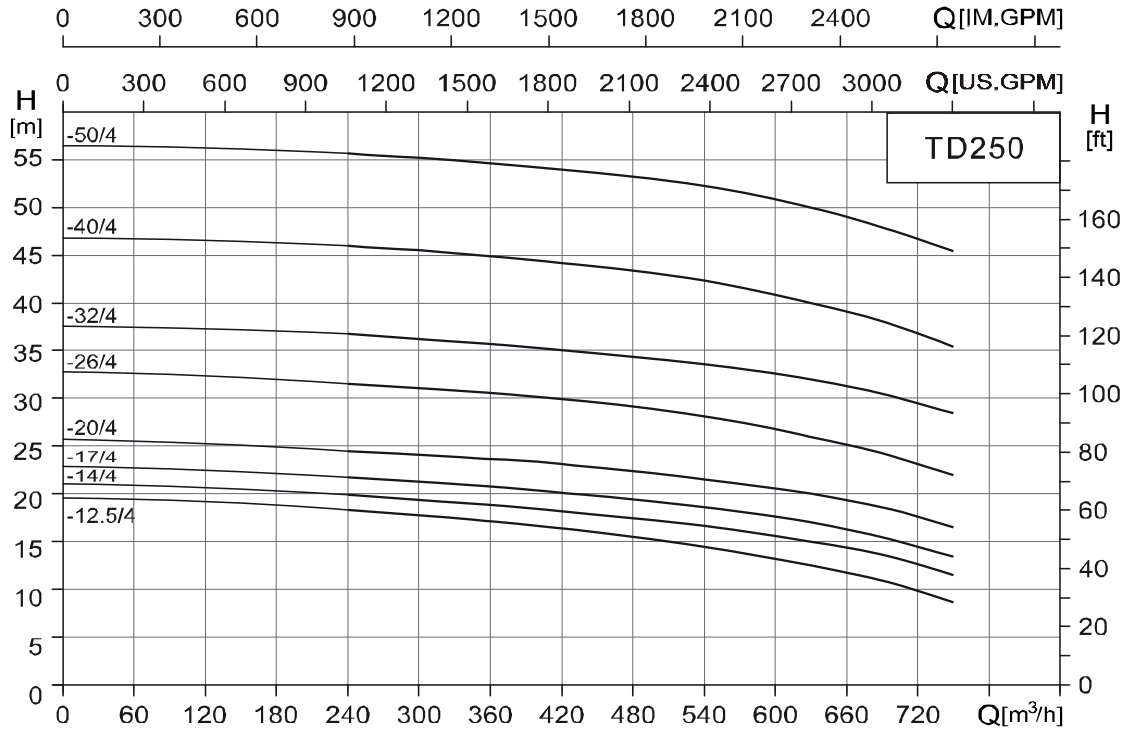

TD250 Performance table

50Hz

Model	Motor (kW)	Q (m³/h)	240	300	360	420	480	540	600	630	660	720	750
TD250-12.5/4	30	H (m)	18.4	17.9	17.2	16.4	15.5	14.5	13.2	12.5	11.8	9.9	8.7
TD250-14/4	37		20	19.5	18.9	18.2	17.5	16.6	15.6	14	13.4	12.6	11.6
TD250-17/4	45		21.8	21.3	20.8	20.1	19.4	18.6	17.6	17	16.3	14.4	13.4
TD250-20/4	55		24.5	24.1	23.7	23.1	22.4	21.5	20.5	20	19.3	17.6	16.5
TD250-26/4	75		31.7	31.1	30.6	29.9	29.1	28.2	26.8	26	25.2	23.1	21.9
TD250-32/4	90		36.7	36.3	35.7	35.1	34.3	33.5	32.6	32	31.3	29.5	28.4
TD250-40/4	110		46	45.5	44.9	44.2	43.4	42.3	40.8	40	39.1	36.8	35.5
TD250-50/4	132		55.6	55.2	54.6	53.9	53.2	52.3	50.9	50	49	46.7	45.4

Installation sketch

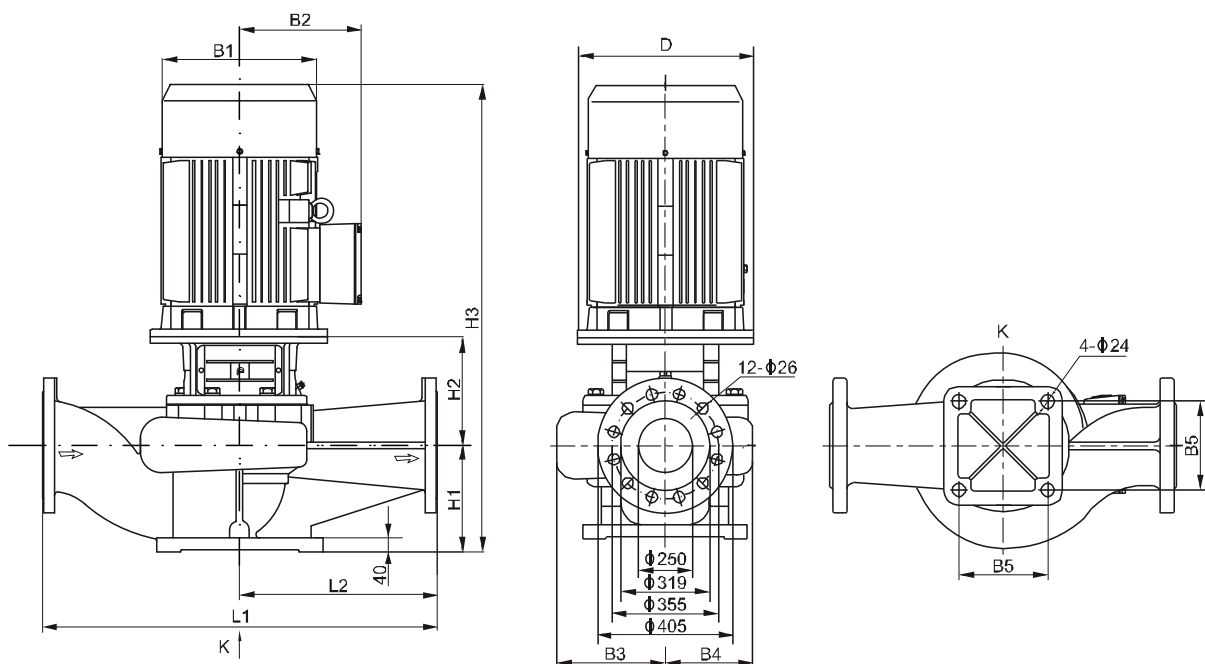

Dimensions and weights

Model	Dimension(mm)											Weight (kg)
	D	B1	B2	B3	B4	B5	H1	H2	H3	L1	L2	
TD250-12.5/4	400	397	314	316	243	390	300	465	1417	1100	550	552
TD250-14/4	450	445	334	316	243	390	300	495	1469	1100	550	613
TD250-17/4	450	445	334	316	243	390	300	495	1492	1100	550	649
TD250-20/4	550	484	367	316	243	390	300	495	1568	1100	550	722
TD250-26/4	550	547	407	329	264	440	300	507	1667	1100	550	909
TD250-32/4	550	547	407	329	264	440	300	507	1687	1100	550	999
TD250-40/4	660	645	535	347	292	440	305	525	1883	1200	600	1389
TD250-50/4	660	645	535	347	292	440	305	525	1990	1200	600	1473

Note: The dimension of single-phase motor and explosion-proof motor will change. Please consult our company for more details.

Performance curve

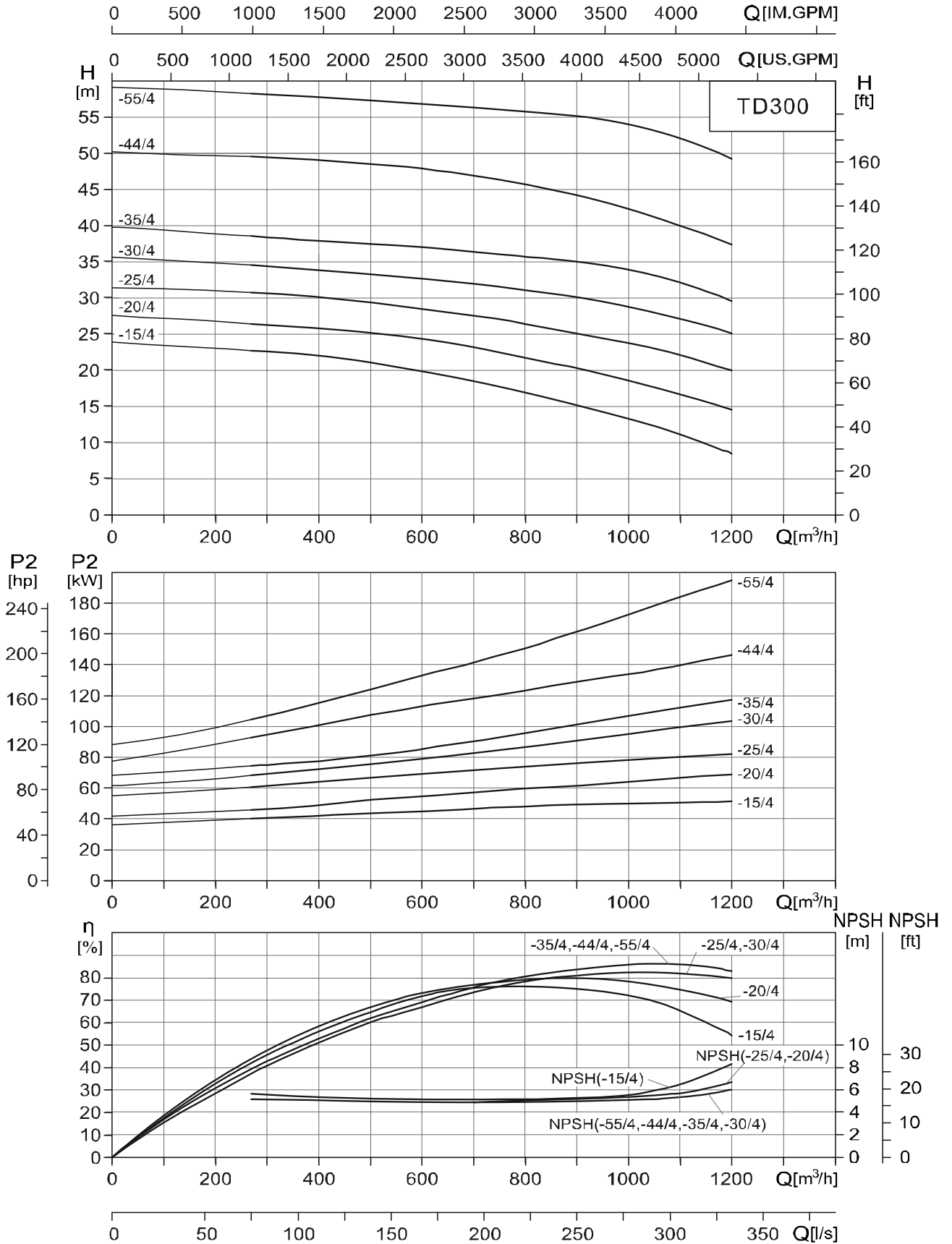

TD300 Performance table

50Hz

Model	Motor (kW)	Q (m³/h)	270	360	450	630	750	900	1080	1200
TD300-15/4	55	H (m)	22.7	22.3	21.6	19.5	17.8	15	11.6	8.5
TD300-20/4	75		26.4	26	25.5	24.1	22.4	20	17.1	14.5
TD300-25/4	90		30.8	30.4	29.8	28.2	27.1	25	22.5	20
TD300-30/4	110		34.5	34	33.5	32.4	31.6	30	27.5	25
TD300-35/4	132		38.6	38.1	37.8	36.9	36	35	32.6	29.6
TD300-44/4	160		49.5	49.2	48.8	47.6	46.3	44	40.5	37.5
TD300-55/4	200		58.2	57.9	57.6	56.7	56.1	55	52.5	49.2

Installation sketch

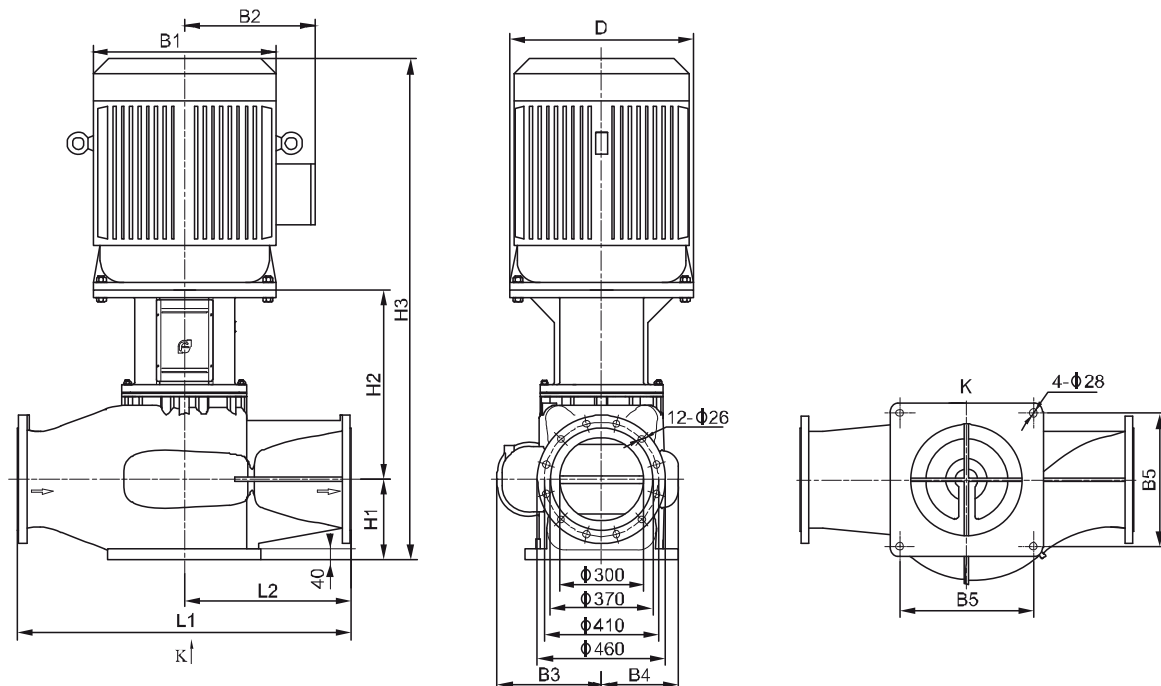

Dimensions and weights

Model	Dimension(mm)											Weight (kg)
	D	B1	B2	B3	B4	B5	H1	H2	H3	L1	L2	
TD300-15/4	550	484	367	345	250	440	285	647	1705	1200	600	907
TD300-20/4	550	547	407	345	250	440	285	647	1792	1200	600	1075
TD300-25/4	550	547	407	380	280	480	290	659	1829	1200	600	1230
TD300-30/4	660	645	535	380	280	480	290	699	2042	1200	600	1570
TD300-35/4	660	645	535	380	280	480	290	699	2149	1200	600	1650
TD300-44/4	660	645	535	380	295	480	290	702	2150	1200	600	1790
TD300-55/4	660	645	535	380	295	480	290	702	2150	1200	600	1905

Note: The dimension of single-phase motor and explosion-proof motor will change. Please consult our company for more details.

Performance curve

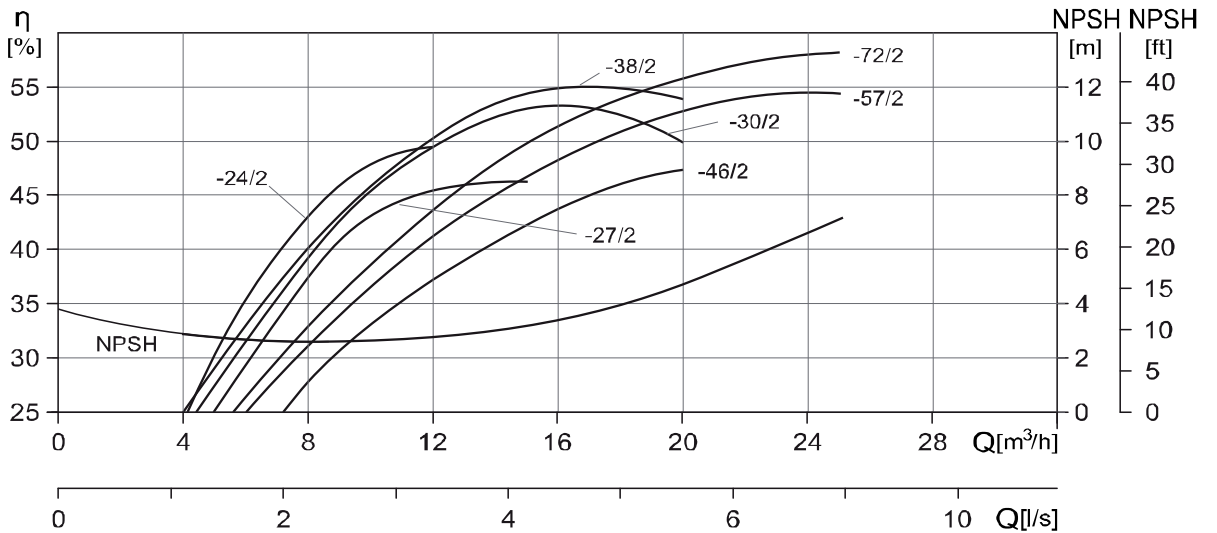
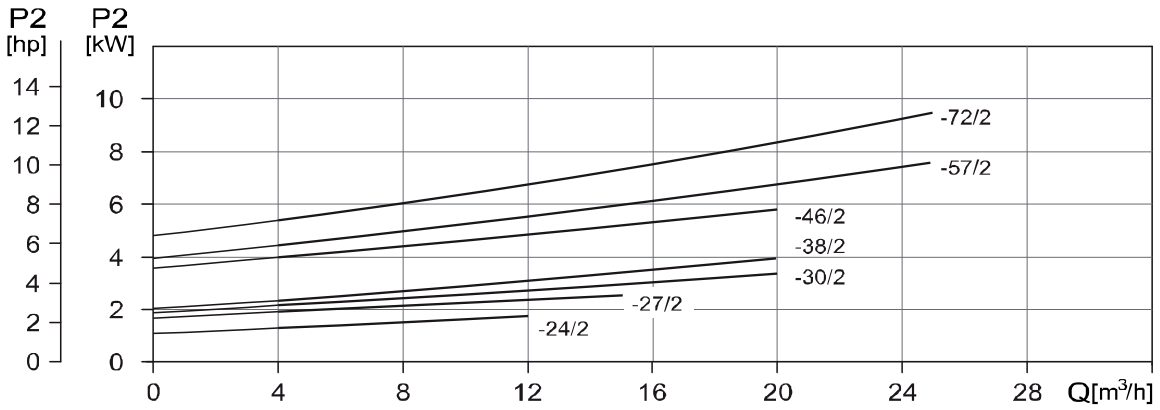
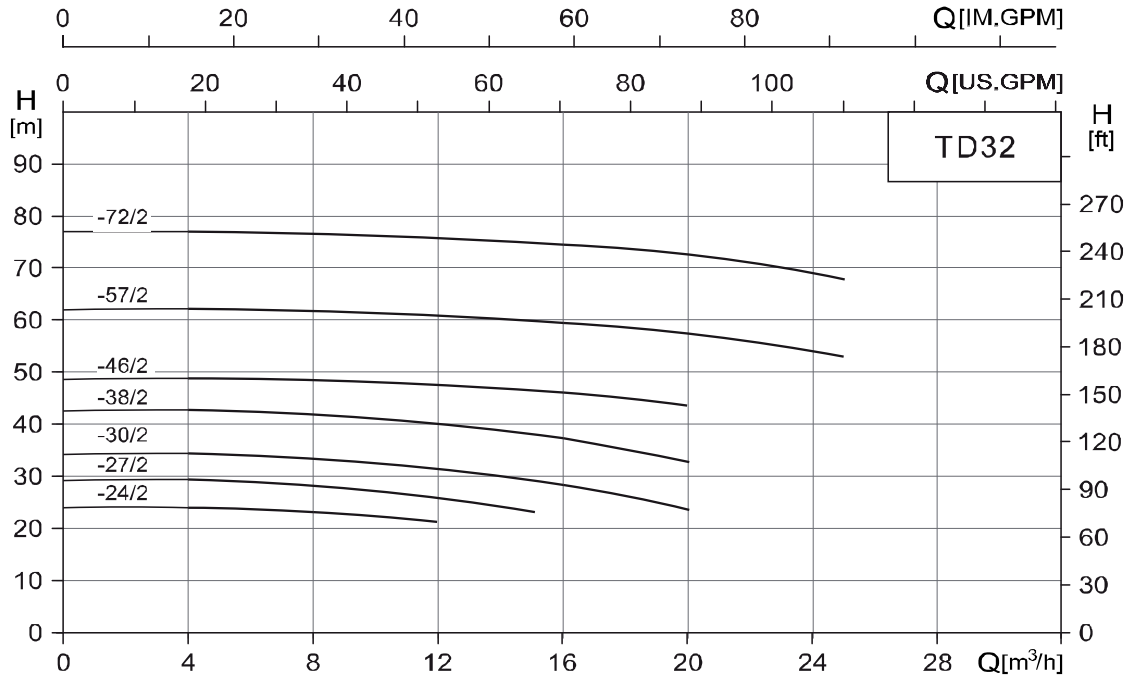

TD32 Performance table

60Hz

Model	Motor		Q (m ³ /h)	4	7	8	10	12	15	20	25
	(kW)	(hp)									
TD32-24/2	1.5	2	H (m)	24.5	24	23	22.5	21			
TD32-27/2	2.2	3		29	28.5	28	27	26	23		
TD32-30/2	3	4		35	34.5	34	33	32	30	23	
TD32-38/2	4	5.5		43	42.5	42	41	40	38	33	
TD32-46/2	5.5	7.5		49	49	49	48.5	48	46	44	
TD32-57/2	7.5	10		62	62	62	61.5	61	59	57	53
TD32-72/2	11	15		77	77	77	76.5	76	75	72	67

Installation sketch

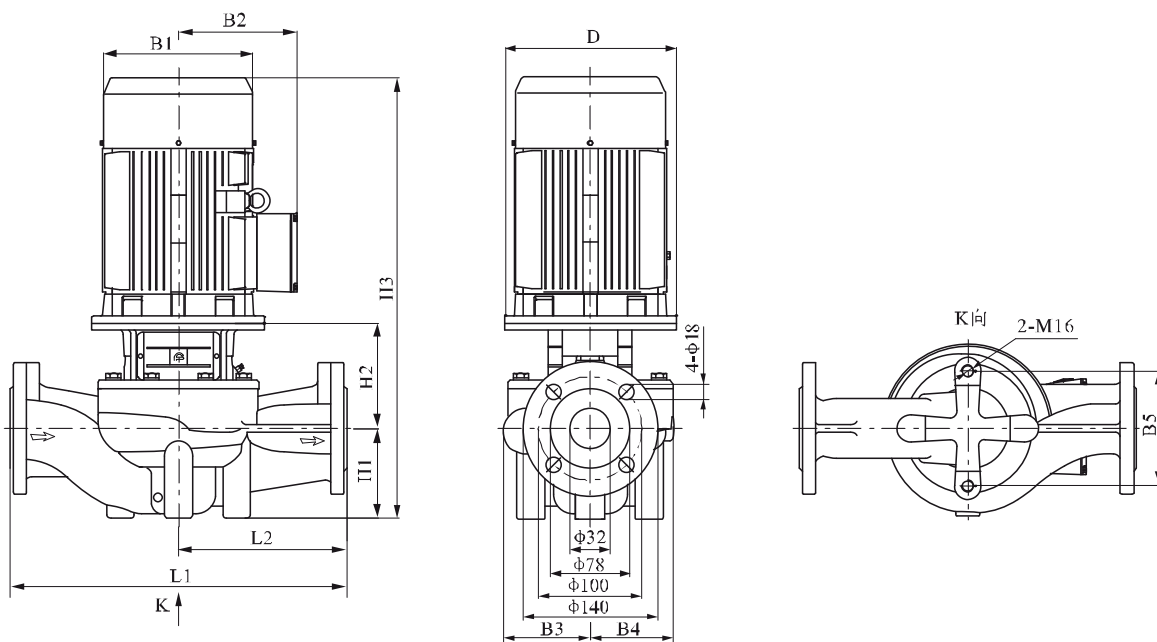

Dimensions and weights

Model	Dimension(mm)											Weight (kg)
	D	B1	B2	B3	B4	B5	H1	H2	H3	L1	L2	
TD32-24/2	140	190	155	115	115	144	100	166	556	340	170	56
TD32-27/2	140	190	155	115	115	144	100	166	556	340	170	59
TD32-30/2	160	197	165	115	115	144	100	185	630	340	170	68
TD32-38/2	160	230	188	129	129	144	100	185	640	440	220	79
TD32-46/2	200	260	208	129	129	144	100	213	703	440	220	104
TD32-57/2	200	260	208	129	129	144	100	213	703	440	220	107
TD32-72/2	350	330	255	129	129	144	100	262	862	440	220	167

Note: The dimension of single-phase motor and explosion-proof motor will change. Please consult our company for more details.

Performance curve

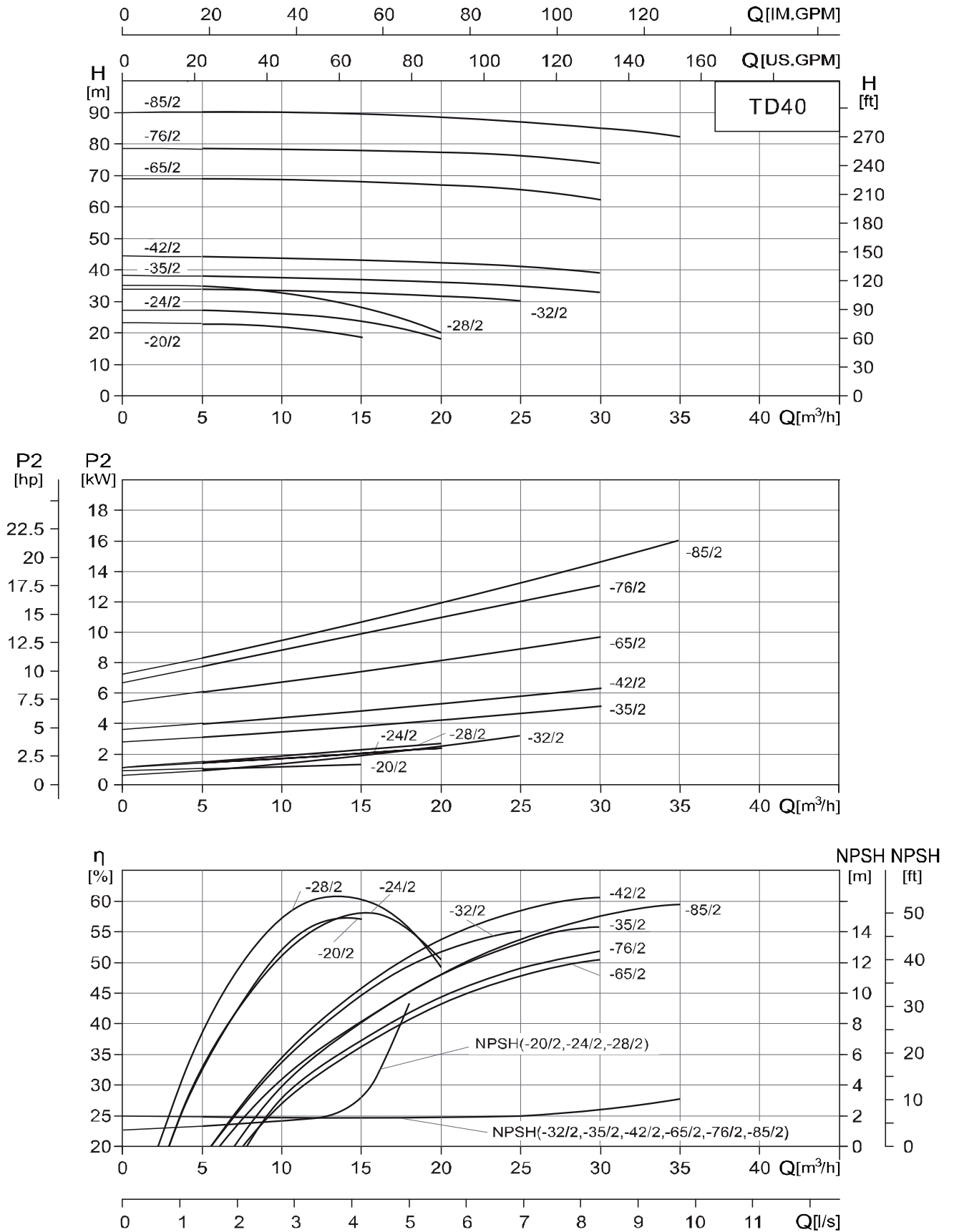

TD40 Performance table

60Hz

Model	Motor		Q (m ³ /h)	5	10	12	15	20	25	30	35
	(kW)	(hp)									
TD40-20/2	1.5	2	H (m)	23	22	20	18				
TD40-24/2	2.2	3		27	26	25.5	24	18			
TD40-28/2	3	4		35	33	31	28	20			
TD40-32/2	4	5.5		34	34	33.5	33	32	30		
TD40-35/2	5.5	7.5		38	38	37.5	37	36	35	33	
TD40-42/2	7.5	10		45	45	44.5	44	43	42	40	
TD40-65/2	11	15		69	69	68.5	68	67	65	63	
TD40-76/2	15	20		79	79	78.5	78	77	76	73	
TD40-85/2	18.5	25		91	91	90.5	90	89	87	85	82

Installation sketch

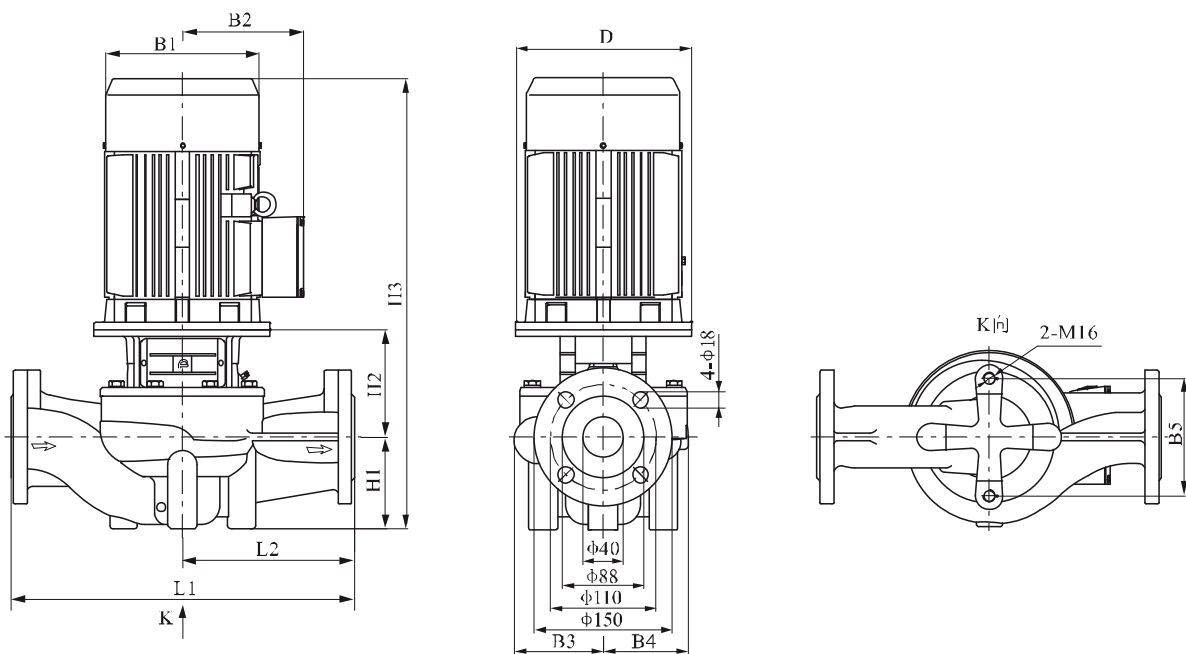

Dimensions and weights

Model	Dimension(mm)											Weight (kg)
	D	B1	B2	B3	B4	B5	H1	H2	H3	L1	L2	
TD40-20/2	140	190	155	97	95	120	68	160	518	320	160	46
TD40-24/2	140	190	155	97	95	120	68	160	518	320	160	53
TD40-28/2	160	197	165	97	95	120	68	178	591	320	160	70
TD40-32/2	160	230	188	138	128	144	100	185	650	440	220	77
TD40-35/2	200	260	208	138	128	144	100	213	713	440	220	106
TD40-42/2	200	260	208	138	128	144	100	213	713	440	220	110
TD40-65/2	350	330	255	138	128	144	100	262	872	440	220	167
TD40-76/2	350	330	255	140	138	144	100	262	872	440	220	178
TD40-85/2	350	330	255	140	138	144	100	262	922	440	220	196

Note: The dimension of single-phase motor and explosion-proof motor will change. Please consult our company for more details.

Performance curve

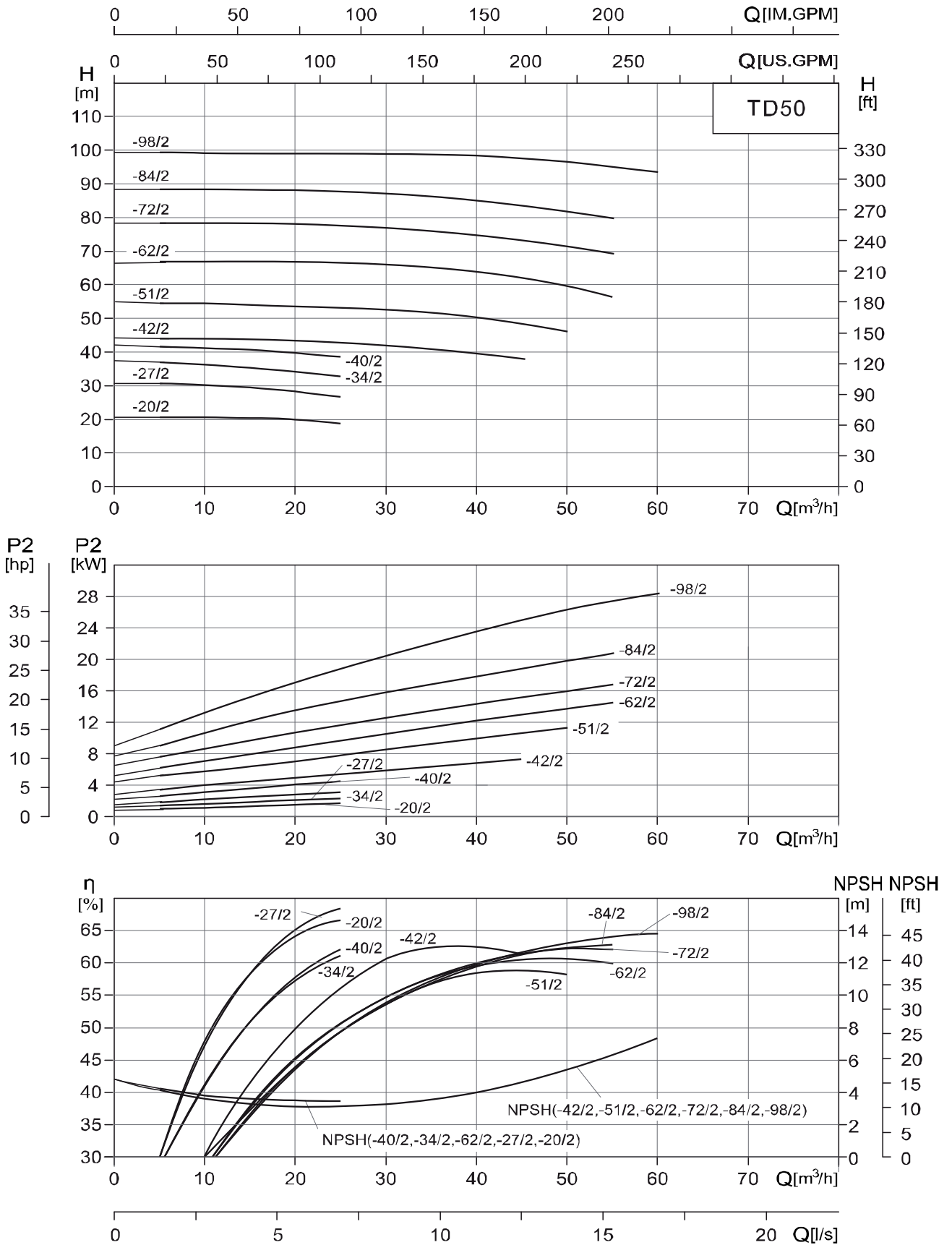

TD50 Performance table

60Hz

Model	Motor		Q (m ³ /h)	H											
	(kW)	(hp)		5	10	15	20	25	30	35	40	45	50	55	60
TD50-20/2	2.2	3	H (m)	21	20.5	20.3	20	18.5							
TD50-27/2	3	4		31	30	28.8	27	26							
TD50-34/2	4	5.5		37	36.2	35.3	34	32.7							
TD50-40/2	5.5	7.5		41.5	41.2	41	40	39							
TD50-42/2	7.5	10		45.5	44	43.5	43	42.5	42	41	40	39			
TD50-51/2	11	15		54	53.5	53	52.5	52.5	52	51	50	48.7	47		
TD50-62/2	15	20		66.5	66.6	66.4	66	65.5	65	64	63	62	59	56	
TD50-72/2	18.5	25		77	77	77.2	77.2	76.5	76	75	73	72	71	69	
TD50-84/2	22	30		88	88	88	88	87.5	87	86	85	84	83	82	
TD50-98/2	30	40		99.1	99.4	99.5	99.6	99.5	99	99	98.5	98.2	98	95.5	93

Installation sketch

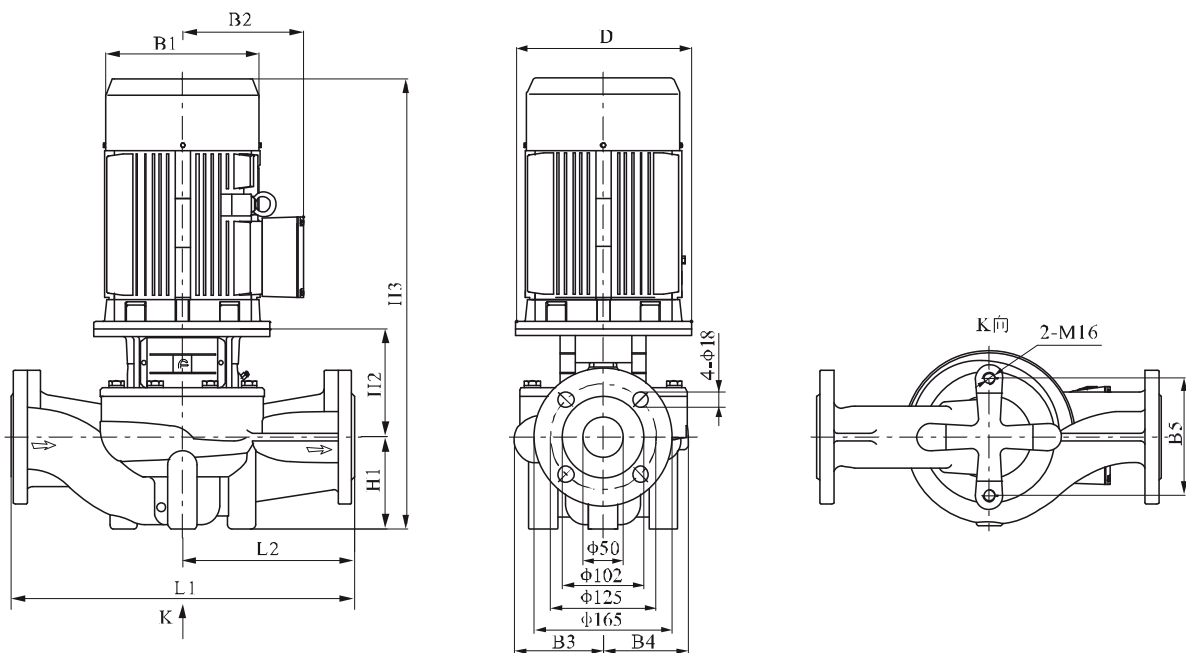

Dimensions and weights

Model	Dimension(mm)											Weight (kg)
	D	B1	B2	B3	B4	B5	H1	H2	H3	L1	L2	
TD50-20/2	140	190	155	117	115	144	115	153	558	340	170	65
TD50-27/2	160	197	165	117	115	144	115	172	632	340	170	74
TD50-34/2	160	230	188	129	115	144	115	172	642	340	170	79
TD50-40/2	200	260	208	129	115	144	115	197	702	340	170	103
TD50-42/2	200	260	208	171	158	144	115	197	702	440	220	118
TD50-51/2	350	330	255	171	158	144	115	250	865	440	220	181
TD50-62/2	350	330	255	171	158	144	115	250	865	440	220	191
TD50-72/2	350	330	255	171	158	144	115	250	915	440	220	209
TD50-84/2	350	360	285	171	158	144	115	250	940	440	220	245
TD50-98/2	400	400	310	171	158	144	115	250	1015	440	220	296

Note: The dimension of single-phase motor and explosion-proof motor will change. Please consult our company for more details.

Performance curve

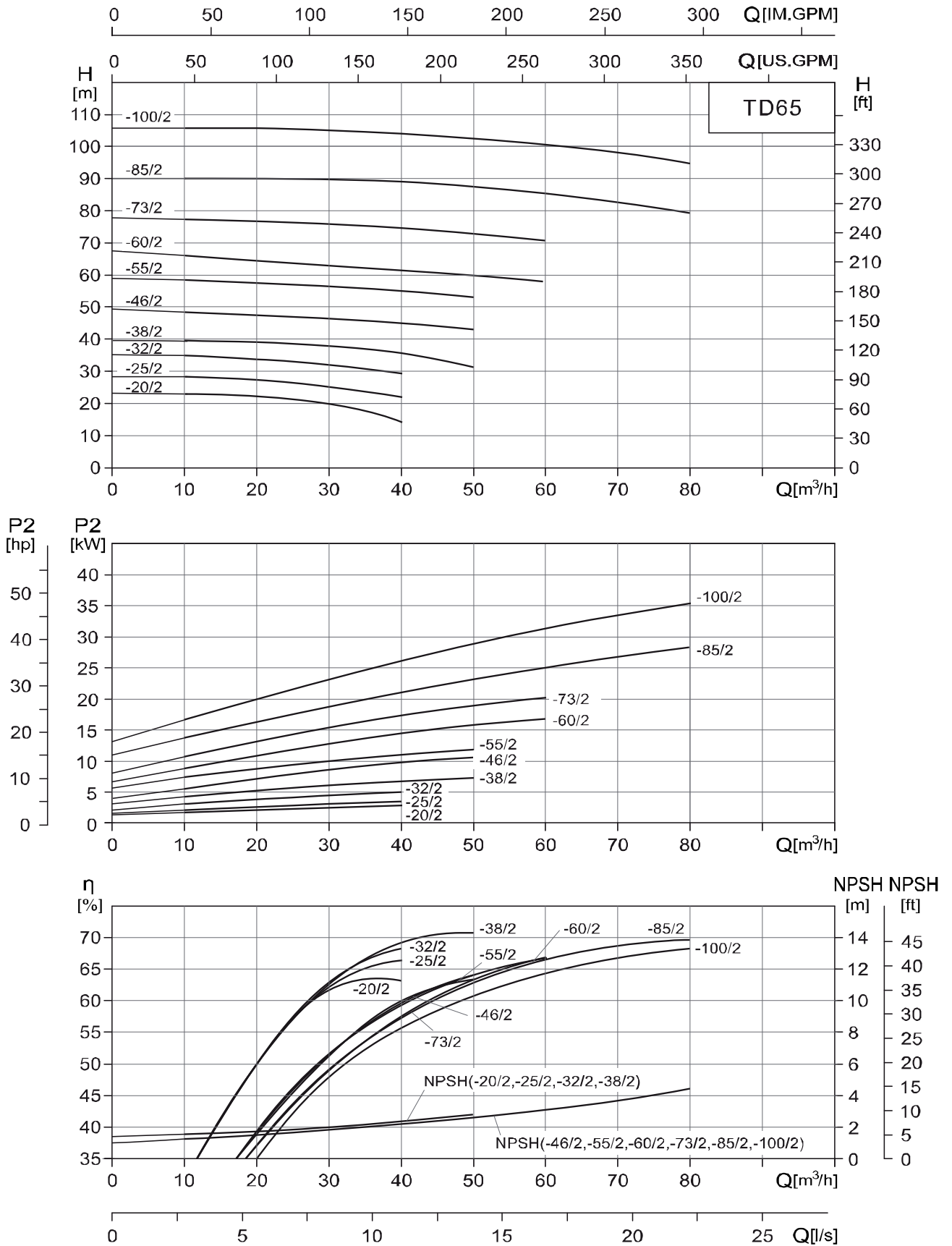

TD65 Performance table

60Hz

Model	Motor		Q (m³/h)	10	20	30	35	40	50	60	70	80
	(kW)	(hp)										
TD65-20/2	3	4	H (m)	22.2	22	20	18	14.3				
TD65-25/2	4	5.5		28	27	25	24	21				
TD65-32/2	5.5	7.5		35	33.5	32	31	29.5				
TD65-38/2	7.5	10		39.5	38.7	38.5	38	36	31.5			
TD65-46/2	11	15		48	47	46.5	46	45	44			
TD65-55/2	15	20		57.3	56.5	56.2	55	54	52			
TD65-60/2	18.5	25		64	63.8	62	61.8	60.5	60	56		
TD65-73/2	22	30		78	77	76.5	76	75.5	73	71		
TD65-85/2	30	40		87.8	88	90	90.5	89.5	88.5	85	83	79
TD65-100/2	37	50		107.6	106	105	104	103	102	100	99.5	94

Installation sketch

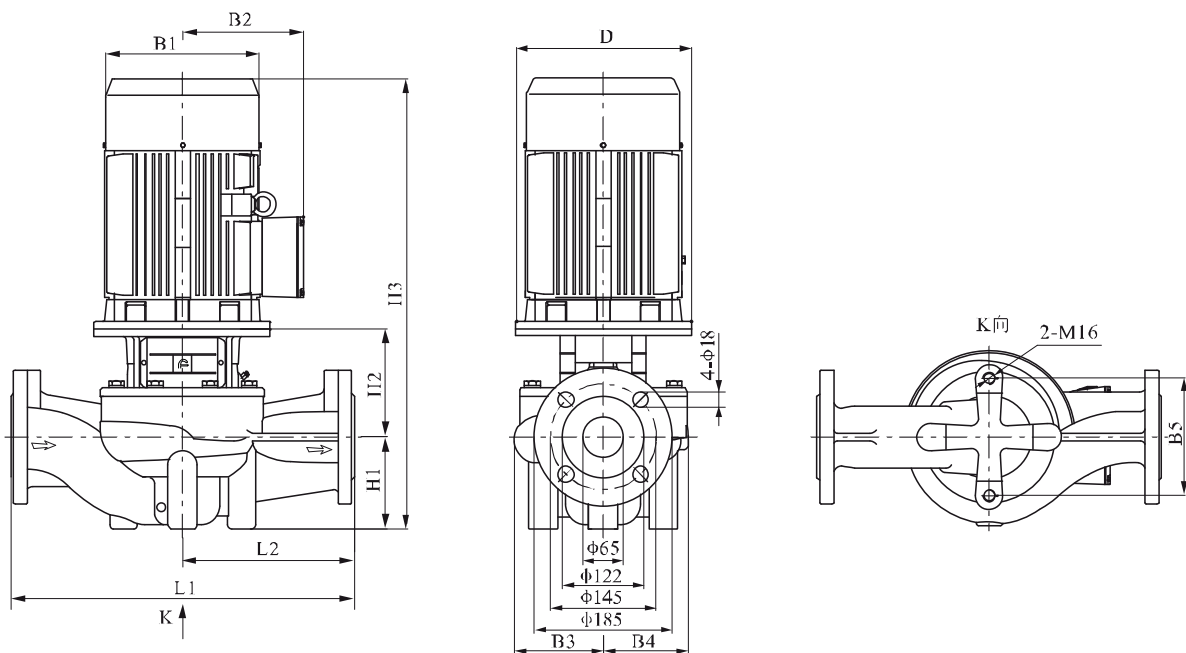

Dimensions and weights

Model	Dimension(mm)											Weight (kg)
	D	B1	B2	B3	B4	B5	H1	H2	H3	L1	L2	
TD65-20/2	160	197	165	142	124	144	105	191	641	360	180	74
TD65-25/2	160	230	188	142	124	144	105	191	651	360	180	81
TD65-32/2	200	260	208	142	124	144	105	213	708	360	180	105
TD65-38/2	200	260	208	142	124	144	105	213	708	360	180	108
TD65-46/2	350	330	255	179	167	144	125	262	887	475	238	183
TD65-55/2	350	330	255	179	167	144	125	262	887	475	238	193
TD65-60/2	350	330	255	179	167	144	125	262	937	475	238	210
TD65-73/2	350	330	255	179	167	144	125	262	962	475	238	248
TD65-85/2	400	400	310	179	167	144	125	262	1037	475	238	309
TD65-100/2	400	400	310	179	167	144	125	262	1037	475	238	328

Note: The dimension of single-phase motor and explosion-proof motor will change. Please consult our company for more details.

Performance curve

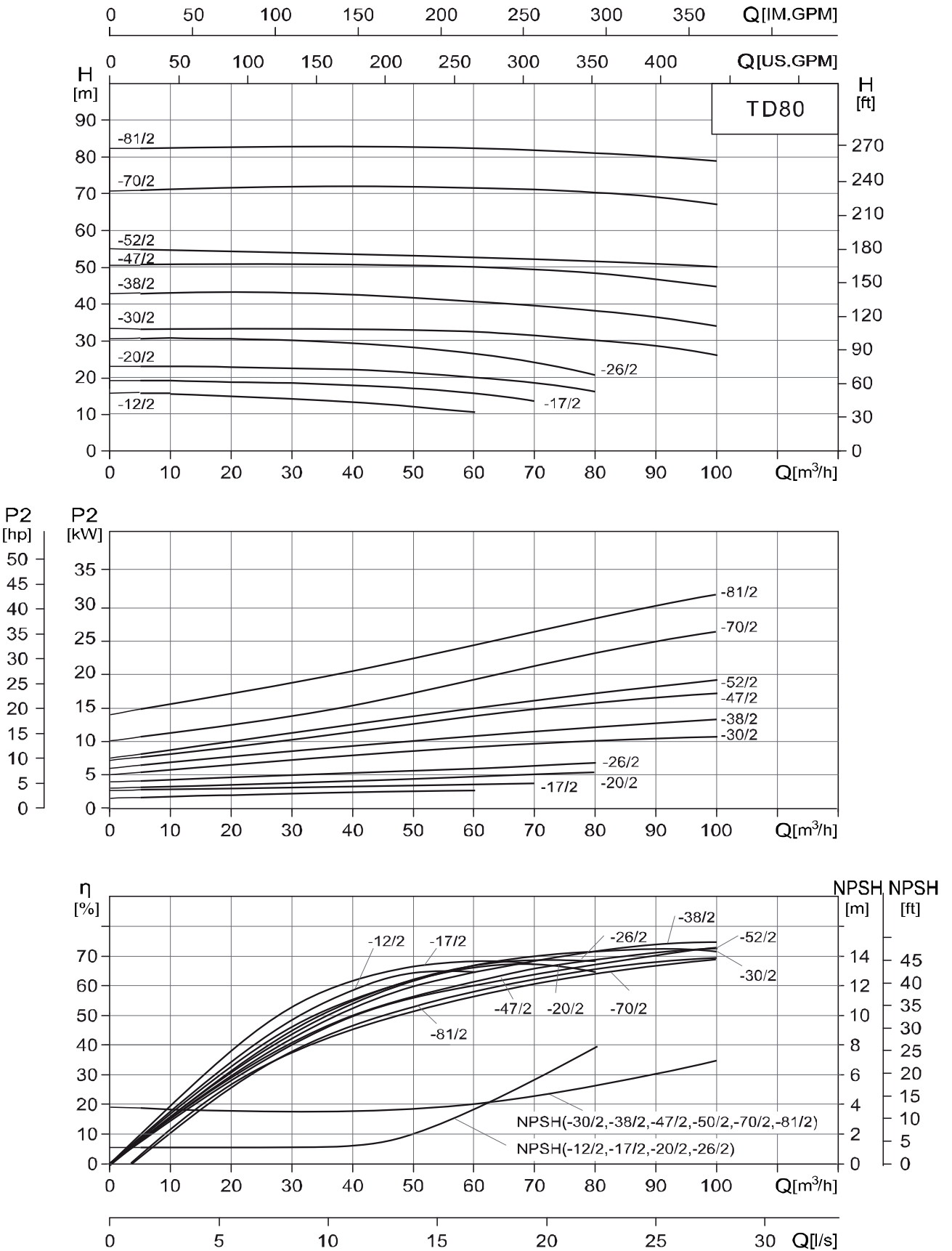

TD80 Performance table

60Hz

Model	Motor		Q (m ³ /h)	5	10	20	30	40	50	60	70	80	90	100	
	(kW)	(hp)													
TD80-12/2	3	4	H (m)	15.2	15.6	15	14.5	13.5	12	10.5					
TD80-17/2	4	5.5		18.5	19	18.6	18.1	17.5	17	15.8	13.5				
TD80-20/2	5.5	7.5		22.5	23	23.6	22.8	22	21.2	20	19	16			
TD80-26/2	7.5	10		30.3	30.6	30.4	30	29	28	26	25	21			
TD80-30/2	11	15		36.8	36.8	36.7	35.8	35.3	34.2	33.1	32.4	30	27.8	23.5	
TD80-38/2	15	20		42.9	43	43.1	43	42.6	42	40.5	39.5	38	36.2	32.3	
TD80-47/2	18.5	25		51.3	51.5	50.9	50.5	50.3	50.2	50	49.4	47	46.5	44.6	
TD80-52/2	22	30		54.7	55.5	55.2	55	54.8	54.5	54.3	53.4	52	50.5	50	
TD80-70/2	30	40		70.9	71.3	71.4	71.8	72	71.9	71.6	71	70	69.3	65	
TD80-81/2	37	50		81.9	82.1	82.8	82.9	82.9	82.7	82.5	82.4	81	80	78	

Installation sketch

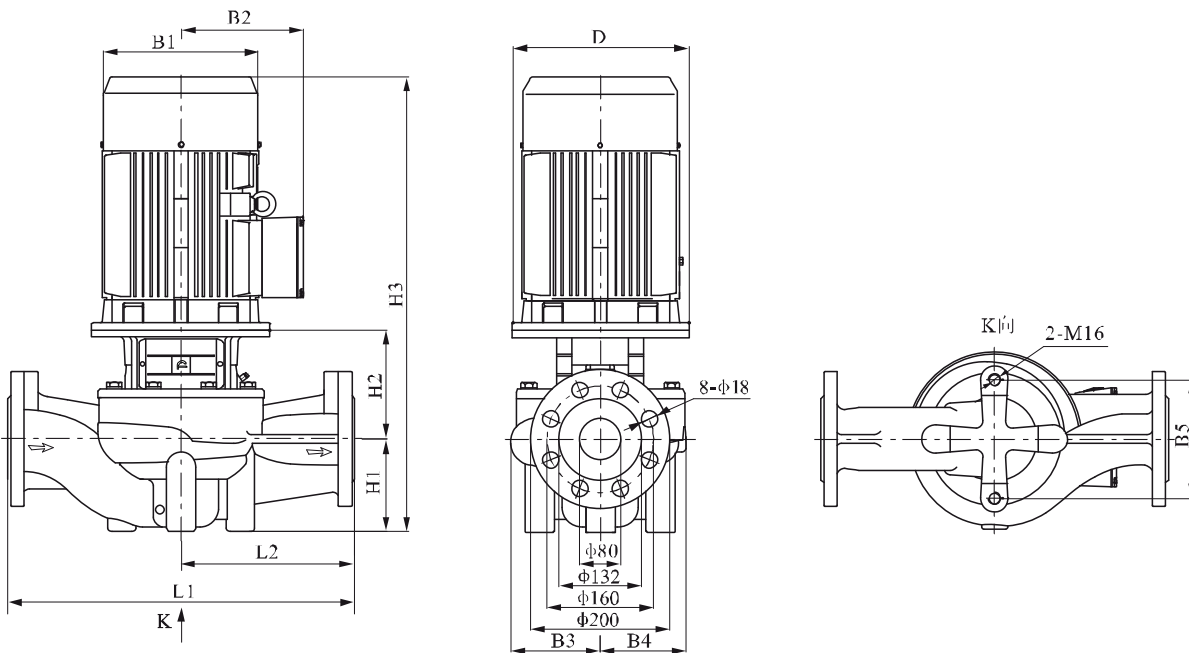

Dimensions and weights

Model	Dimension(mm)											Weight (kg)
	D	B1	B2	B3	B4	B5	H1	H2	H3	L1	L2	
TD80-12/2	160	197	165	142	124	160	97	219	661	450	225	84
TD80-17/2	160	230	188	142	124	160	97	219	671	450	225	91
TD80-20/2	160	260	210	142	124	160	97	241	728	450	225	114
TD80-26/2	160	260	210	142	124	160	97	241	728	450	225	117
TD80-30/2	350	330	255	182	163	144	115	279	894	500	250	194
TD80-38/2	350	330	255	182	163	144	115	279	894	500	250	204
TD80-47/2	350	330	255	182	163	144	115	279	944	500	250	222
TD80-52/2	350	330	255	182	163	144	115	279	969	500	250	258
TD80-70/2	400	400	310	182	163	144	115	279	1044	500	250	319
TD80-81/2	400	400	310	182	163	144	115	279	1044	500	250	338

Note: The dimension of single-phase motor and explosion-proof motor will change. Please consult our company for more details.

Performance curve

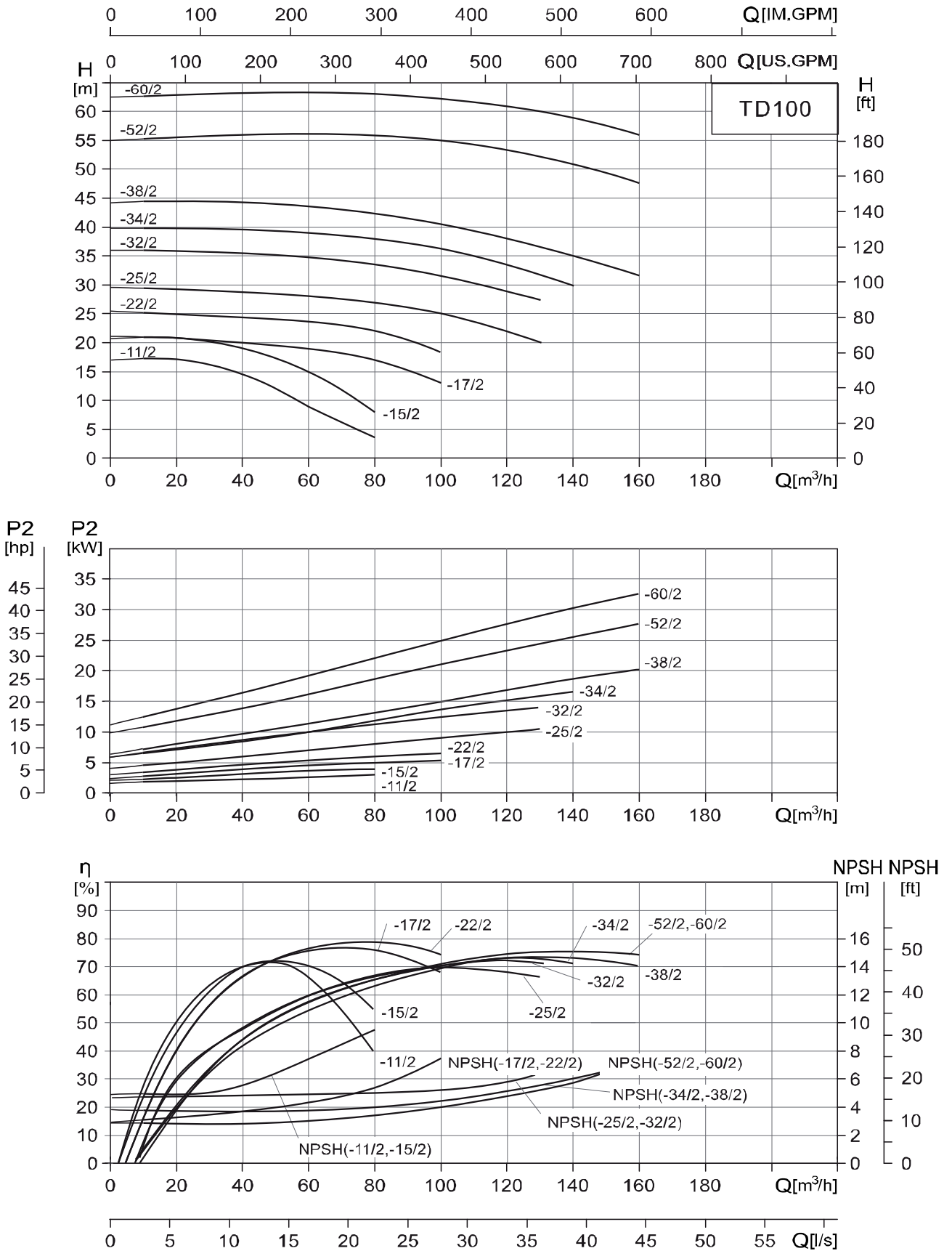

TD100 Performance table

60Hz

Model	Motor		Q (m ³ /h)	H											
	(kW)	(hp)		10	20	40	50	60	80	100	120	130	140	160	
TD100-11/2	3	4	H (m)	17.2	17.1	14.6	11	9	6.3						
TD100-15/2	4	5.5		20.7	20.8	17.9	16.8	15	8						
TD100-17/2	5.5	7.5		21.1	20.8	20	19.8	19.2	17	13					
TD100-22/2	7.5	10		25.6	25.4	24.4	24	23.5	22	18.4					
TD100-25/2	11	15		29.1	29.5	28.8	28.5	27.8	26.6	25	19.8	19.4			
TD100-32/2	15	20		36	36.6	35.6	35.5	34.6	33.5	32	28.9	25.5			
TD100-34/2	18.5	25		39.4	39.4	39.5	39.2	39	37.8	36.2	34	33.4	31		
TD100-38/2	22	30		43.7	44.5	44.2	44	43.8	42.5	40.5	38	36.4	35	30.8	
TD100-52/2	30	40		55	55.8	55.9	56.1	55.9	55.5	55	53.6	52	50.9	47.6	
TD100-60/2	37	50		62	62.9	63.3	63.5	63.2	63	62	60.6	60	57.6	54	

Installation sketch

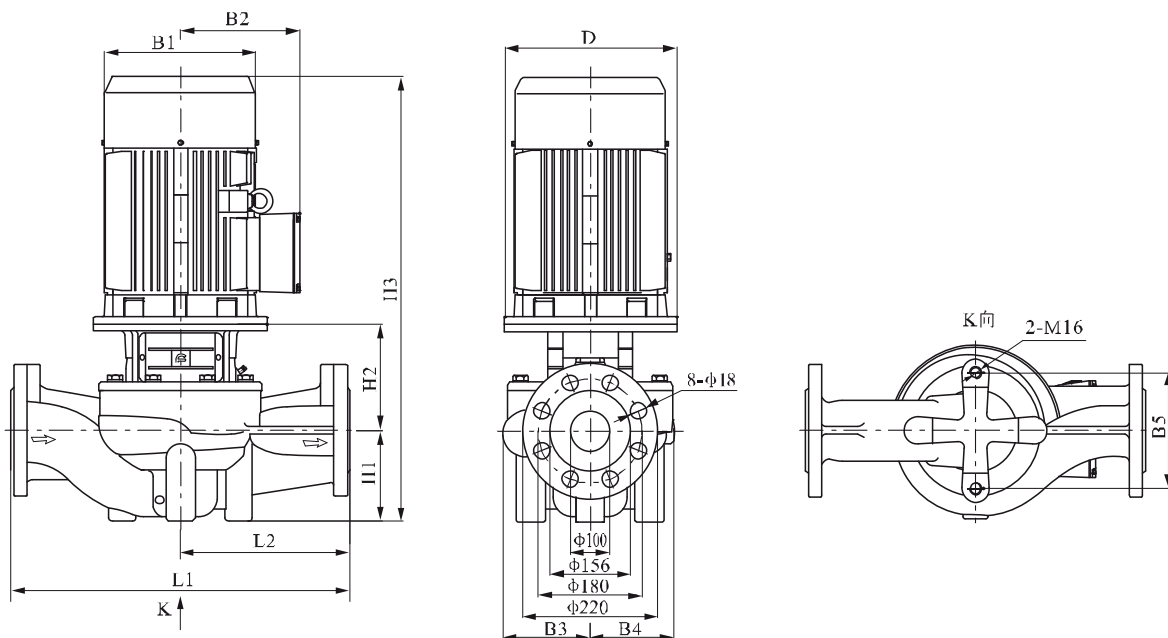

Dimensions and weights

Model	Dimension(mm)											Weight (kg)
	D	B1	B2	B3	B4	B5	H1	H2	H3	L1	L2	
TD100-11/2	160	215	190	134	101	160	105	190	640	450	225	65
TD100-15/2	160	215	190	134	101	160	105	190	650	450	225	83
TD100-17/2	200	260	205	150	117	144	140	215	745	500	250	119
TD100-22/2	200	260	205	150	117	144	140	215	745	500	250	122
TD100-25/2	350	350	245	181	152	230	140	270	910	550	275	197
TD100-32/2	350	350	265	181	152	230	140	270	910	550	275	207
TD100-34/2	350	350	265	181	152	230	140	270	960	550	275	224
TD100-38/2	350	350	280	181	152	230	140	270	985	550	275	260
TD100-52/2	400	400	305	181	152	230	140	270	1060	550	275	318
TD100-60/2	400	400	305	181	152	230	140	270	1060	550	275	337

Note: The dimension of single-phase motor and explosion-proof motor will change. Please consult our company for more details.

Performance curve

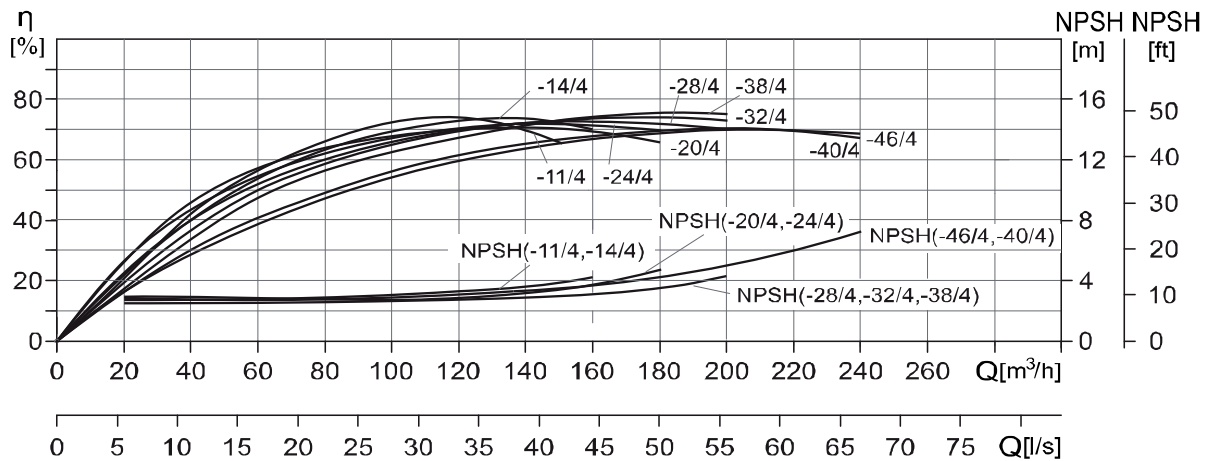
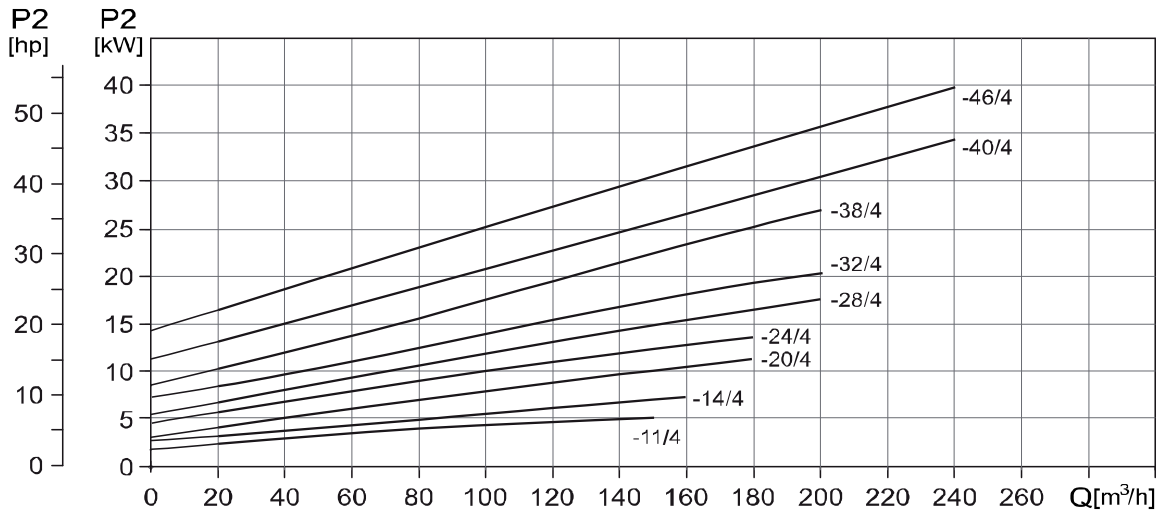
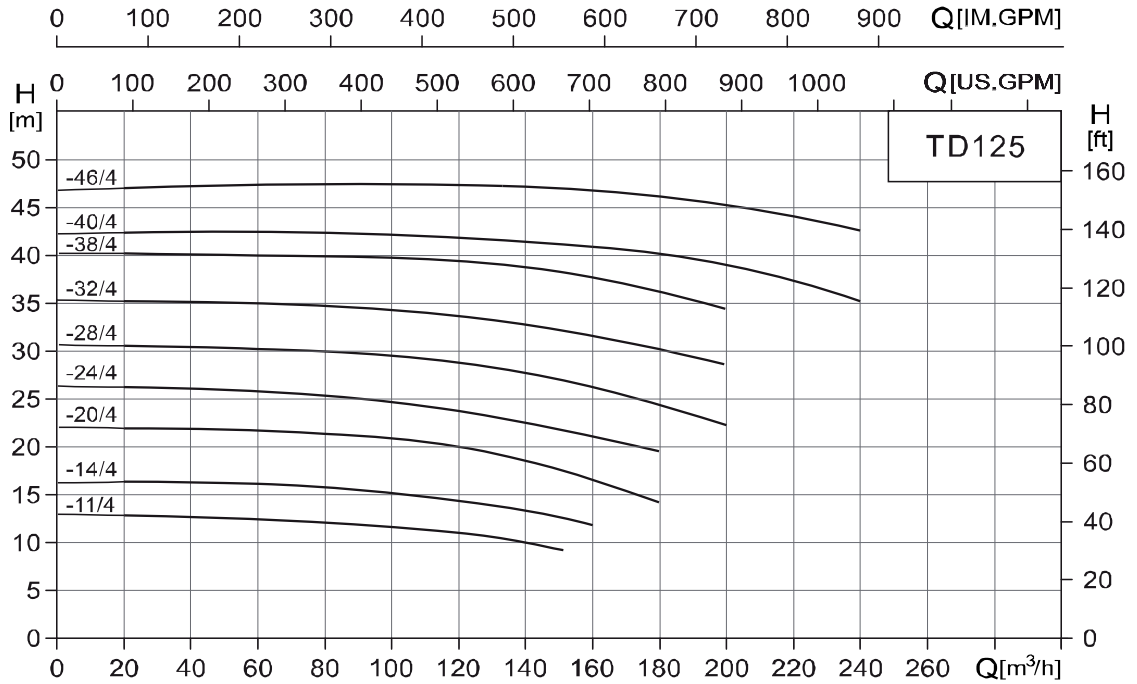

TD125 Performance table

60Hz

Model	Motor		Q (m ³ /h)	H (m)												
	(kW)	(hp)		20	40	60	80	100	120	140	150	160	180	200	220	240
TD125-11/4	5.5	7.5	H (m)	12.9	12.7	12.6	12.2	11.6	11	10	9					
TD125-14/4	7.5	10		16.2	16.1	16	15.9	15.3	14	13.8	12.6	12.5				
TD125-20/4	11	15		21.8	21.4	21.2	21	20.6	20	18	17.4	16.4	14.5			
TD125-24/4	15	20		26.2	25.9	25.7	25.5	24.8	24	22.9	22	21.2	19.8			
TD125-28/4	18.5	25		30.4	30.2	30.1	29.9	29.4	28.6	28	27.3	26.6	24.5	22.5		
TD125-32/4	22	30		35.2	34.9	34.8	34.5	34.2	33.5	32.7	32	31.3	30.1	27.8		
TD125-38/4	30	40		40.2	40.1	40	39.9	39.8	39.5	38.6	38	37.8	36.2	33.8		
TD125-40/4	37	50		42.6	42.8	42.9	42.7	42.4	41.9	41.3	41	40.7	40	38.9	37.4	35.6
TD125-46/4	45	60		47.2	47.4	47.6	47.7	47.6	47.5	47.2	46.9	46.7	46	45.1	44.1	42.8

Installation sketch

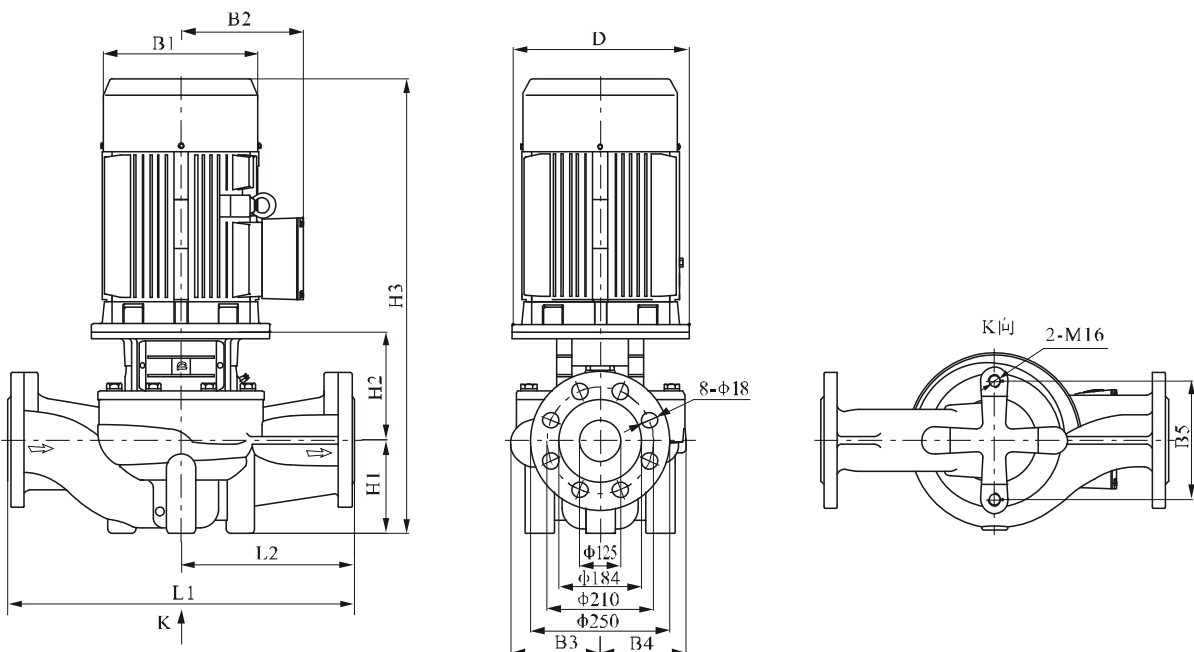

Dimensions and weights

Model	Dimension(mm)											Weight (kg)
	D	B1	B2	B3	B4	B5	H1	H2	H3	L1	L2	
TD125-11/4	200	260	208	216	176	230	215	228	832	620	310	166
TD125-14/4	200	260	208	216	176	230	215	228	832	620	310	169
TD125-20/4	350	330	255	236	208	230	215	298	1011	800	400	292
TD125-24/4	350	330	255	236	208	230	215	298	1053	800	400	302
TD125-28/4	350	330	255	236	208	230	215	298	1090	800	400	321
TD125-32/4	350	330	255	236	208	230	215	298	1128	800	400	356
TD125-38/4	400	400	310	236	208	230	215	298	1162	800	400	416
TD125-40/4	450	450	325	272	248	230	215	314	1203	800	400	499
TD125-46/4	450	450	325	272	248	230	215	314	1226	800	400	536

Note: The dimension of single-phase motor and explosion-proof motor will change. Please consult our company for more details.

Performance curve

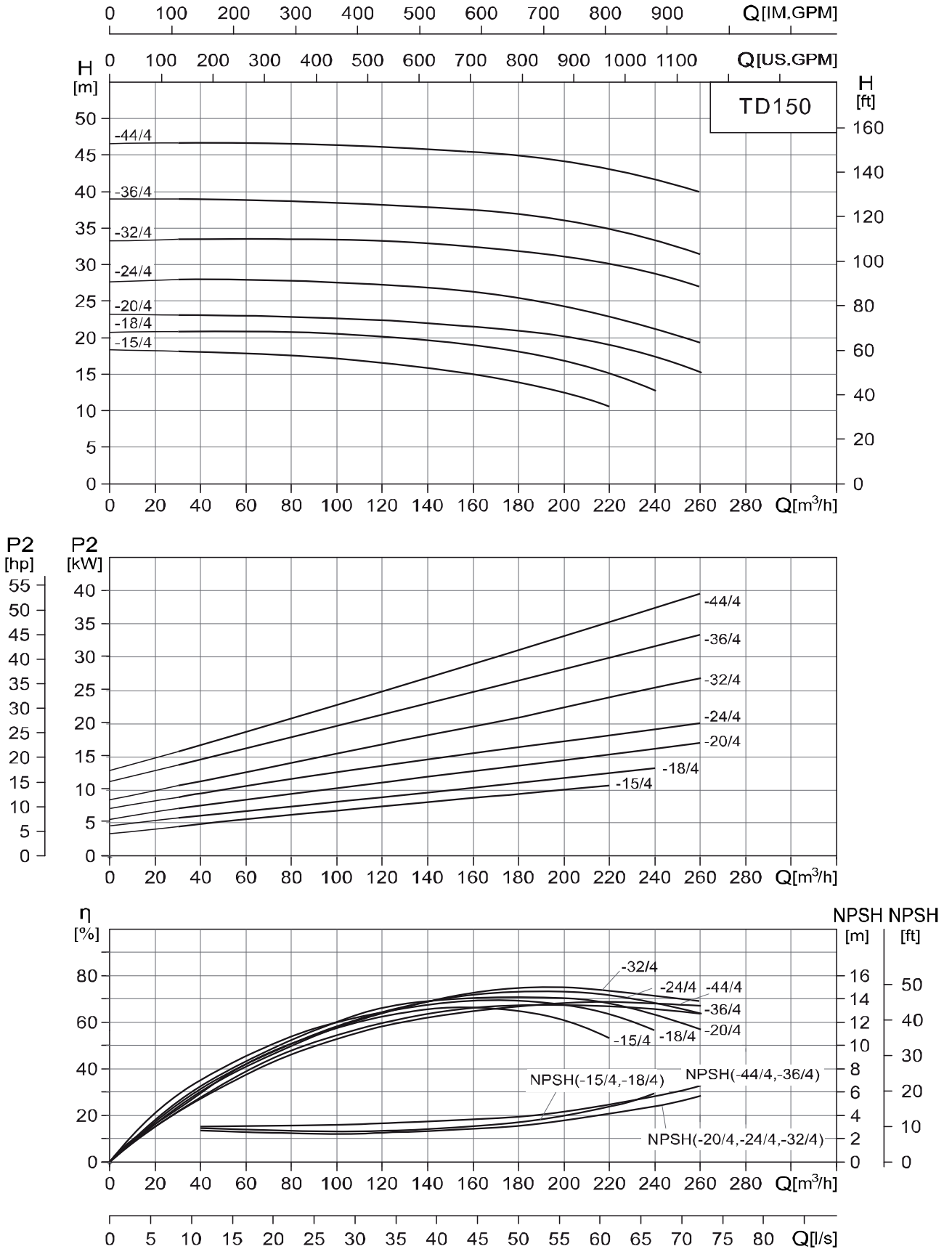

TD150 Performance table

60Hz

Model	Motor		Q (m³/h)	30	60	90	120	140	160	180	200	220	240	260
	(kW)	(hp)												
TD150-15/4	11	15	H (m)	19.1	18.4	17.6	16.7	15.9	15	14.1	12.7	10.5		
TD150-18/4	15	20		21.6	21.3	20.8	20.1	19.5	18.8	18	16.9	15.4	12.6	
TD150-20/4	18.5	25		24	23.6	23.3	22.9	22.4	21.7	20.9	20	18.9	17.4	15.6
TD150-24/4	22	30		27	27.2	27.1	26.8	26.3	25.8	24.9	24	22.8	21.5	19.9
TD150-32/4	30	40		34.2	34.4	34.6	34.4	34	33.5	32.8	32	30.9	29.4	27.3
TD150-36/4	37	50		39.7	39.3	38.8	38.2	37.8	37.3	36.7	36	34.9	33.6	31.9
TD150-44/4	45	60		47.3	47.4	47.2	46.8	46.4	45.8	45	44	42.9	41.7	40.2

Installation sketch

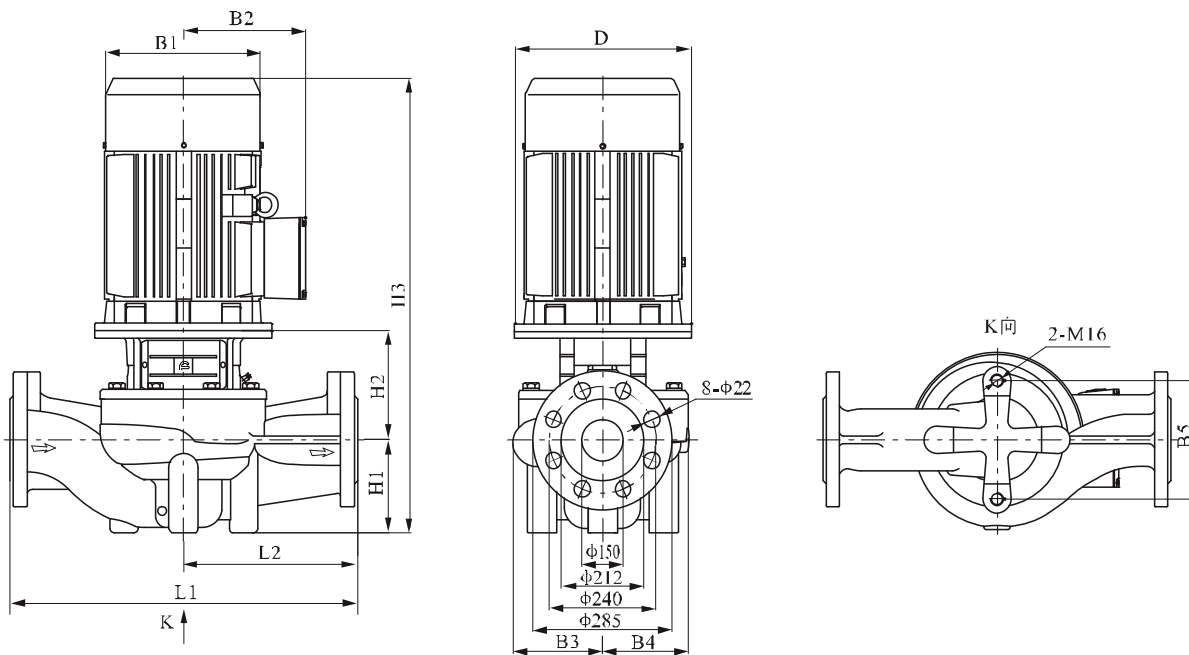

Dimensions and weights

Model	Dimension(mm)											Weight (kg)
	D	B1	B2	B3	B4	B5	H1	H2	H3	L1	L2	
TD150-15/4	350	315	250	238	208	230	215	269	982	800	400	280
TD150-18/4	350	315	250	238	208	230	215	269	1024	800	400	300
TD150-20/4	350	360	275	238	208	230	215	269	1061	800	400	336
TD150-24/4	350	360	275	238	208	230	215	269	1099	800	400	352
TD150-32/4	400	400	305	238	208	230	215	269	1133	800	400	403
TD150-36/4	450	450	325	267	248	230	230	288	1192	900	450	508
TD150-44/4	450	450	325	267	248	230	230	288	1215	900	450	545

Note: The dimension of single-phase motor and explosion-proof motor will change. Please consult our company for more details.

Performance curve

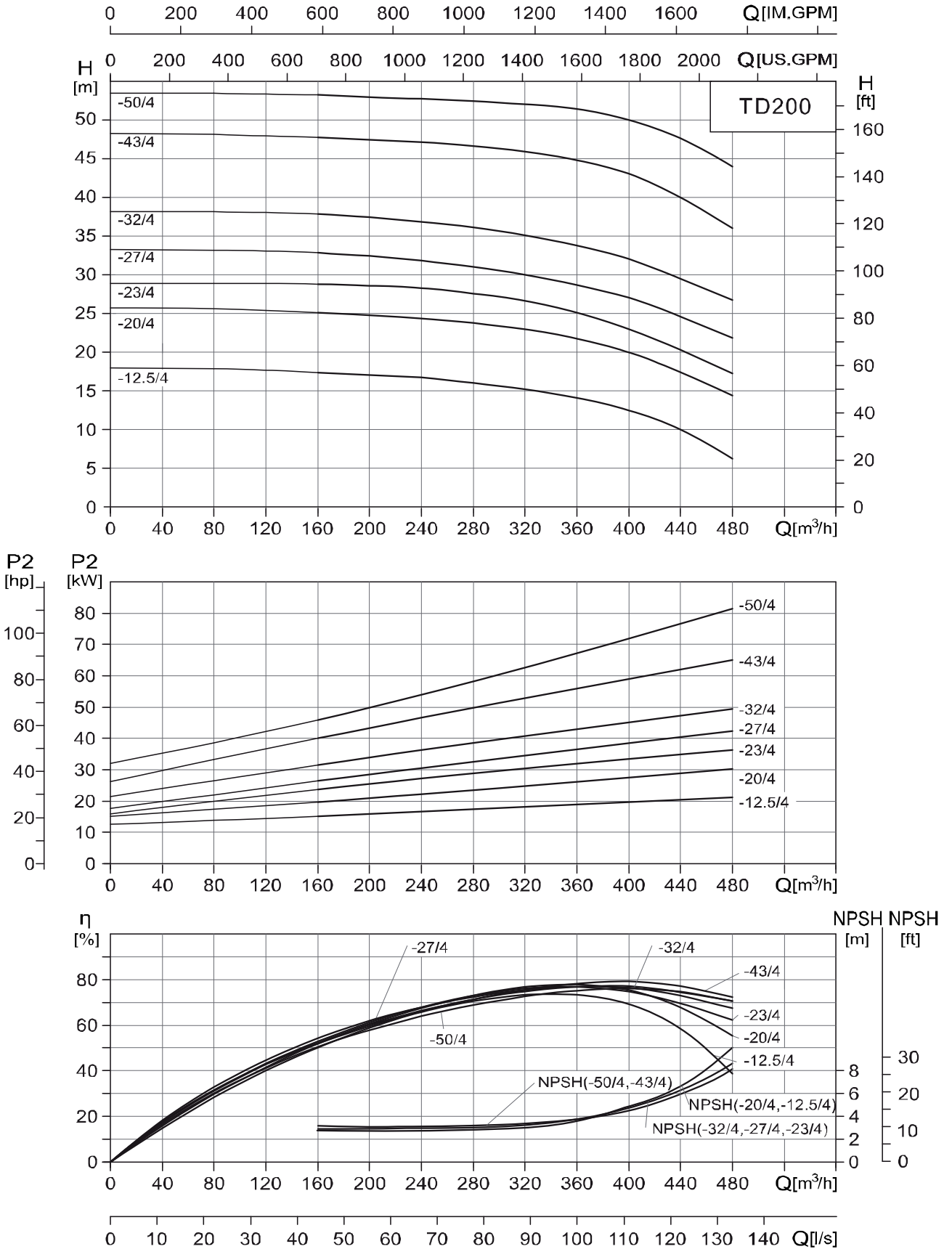

TD200 Performance table

60Hz

Model	Motor		Q (m ³ /h)	160	200	240	280	320	360	400	440	480
	(kW)	(hp)										
TD200-12.5/4	22	30	H (m)	17.4	17.1	16.7	16	15.2	14.1	12.5	10	6.3
TD200-20/4	30	40		25.1	24.8	24.3	23.8	23	21.8	20	17.5	14.9
TD200-23/4	37	50		28.8	28.6	28.3	27.6	26.6	25.1	23	20.3	17.3
TD200-27/4	45	60		32.8	32.4	31.8	31	30	28.7	27	24.6	21.8
TD200-32/4	55	75		37.8	37.4	36.8	36.1	35.1	33.8	32	29.5	26.7
TD200-43/4	75	100		47.7	47.4	47.1	46.6	45.9	44.8	43	40	36
TD200-50/4	90	120		53.2	52.9	52.7	52.4	52	51.4	50	47.6	44

Installation sketch

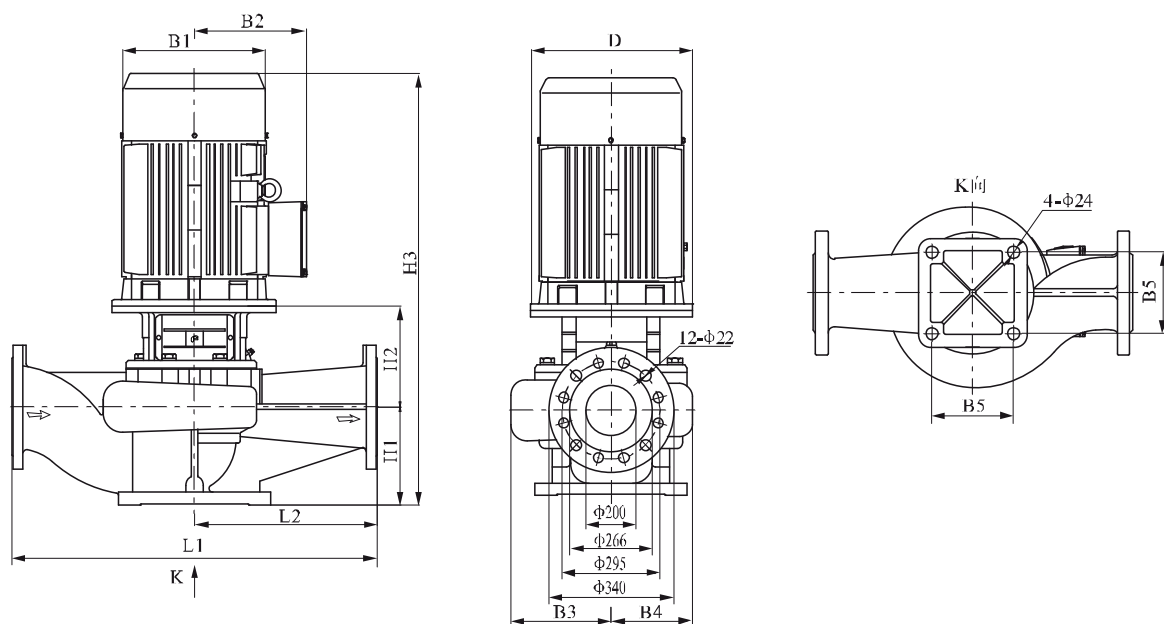

Dimensions and weights

Model	Dimension(mm)											Weight (kg)
	D	B1	B2	B3	B4	B5	H1	H2	H3	L1	L2	
TD200-12.5/4	350	360	280	278	219	360	270	415	1300	1000	500	431
TD200-20/4	400	400	305	278	219	360	270	415	1334	1000	500	490
TD200-23/4	450	450	335	303	252	360	270	445	1389	1100	550	600
TD200-27/4	450	450	335	303	252	360	270	445	1412	1100	550	636
TD200-32/4	550	490	365	303	252	360	270	445	1488	1100	550	707
TD200-43/4	550	550	400	315	269	360	270	457	1556	1100	550	880
TD200-50/4	550	550	400	315	269	360	270	457	1607	1100	550	971

Note: The dimension of single-phase motor and explosion-proof motor will change. Please consult our company for more details.

Performance curve

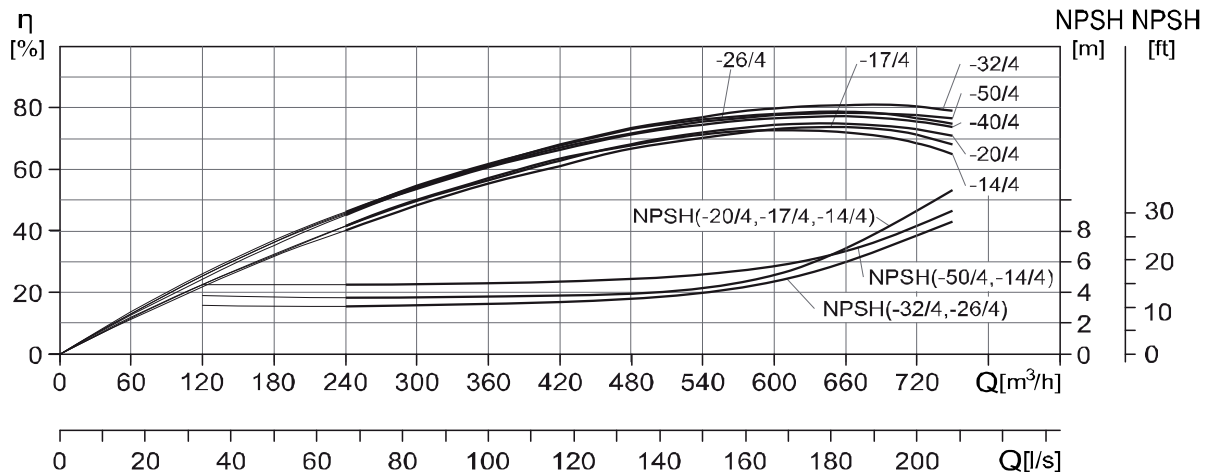
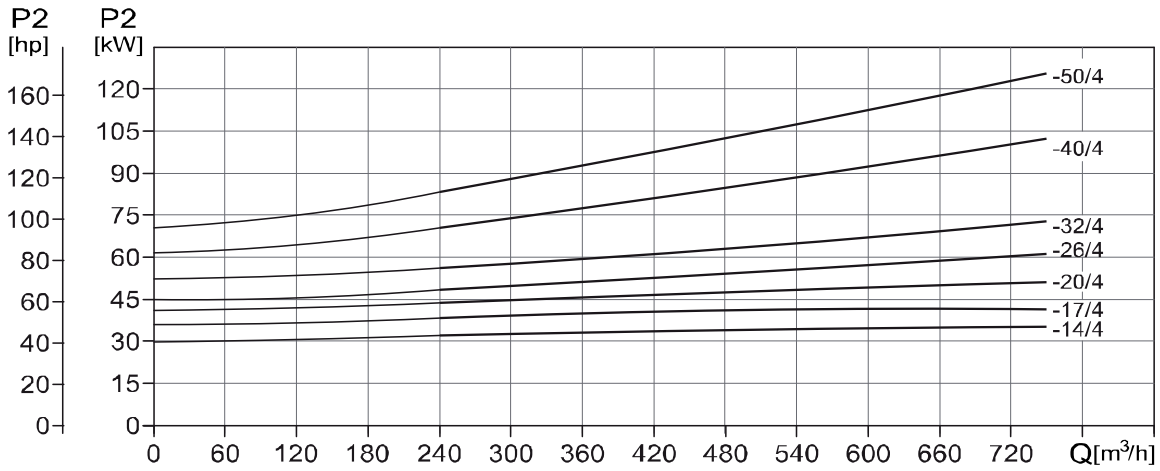
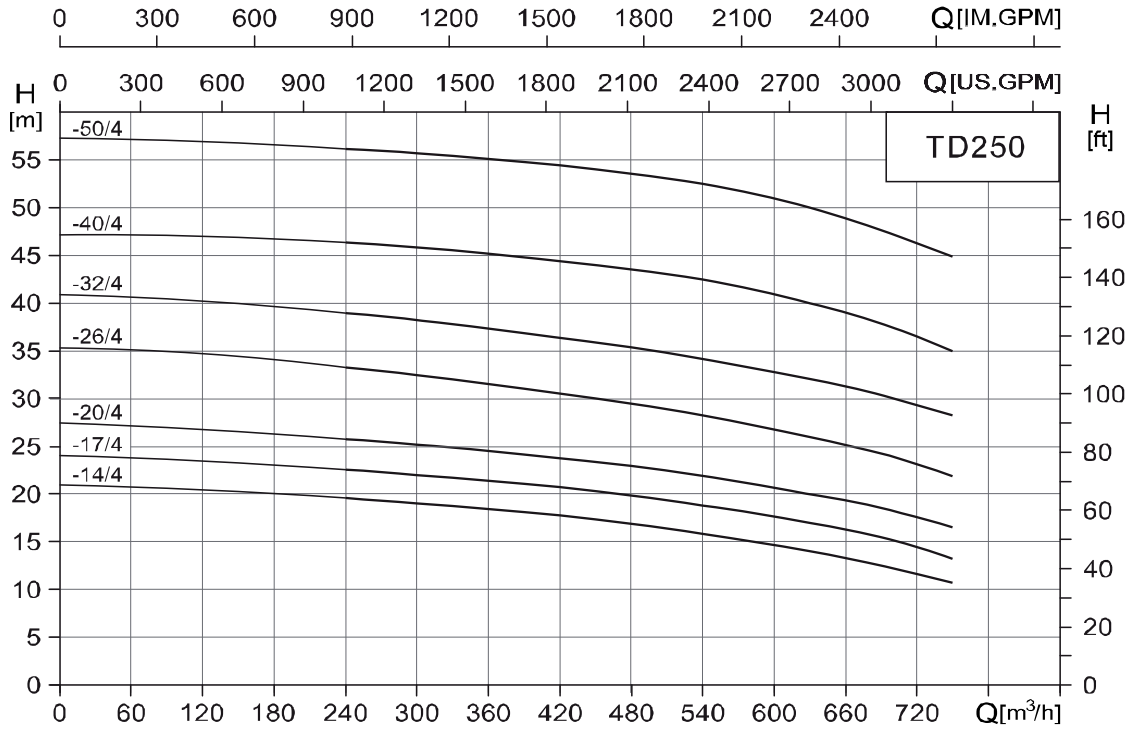

TD250 Performance table

60Hz

Model	Motor		Q (m³/h)	240	300	360	420	480	540	600	630	660	720	750
	(kW)	(hp)												
TD250-14/4	37	50	H (m)	19.6	19.1	18.4	17.7	16.8	15.9	14.6	14	13.3	11.6	10.7
TD250-17/4	45	60		22.5	22.1	21.4	20.7	19.9	18.9	17.6	17	16.3	14.4	13.2
TD250-20/4	55	75		25.8	25.2	24.5	23.7	22.9	21.9	20.6	20	19.3	17.6	16.5
TD250-26/4	75	100		33.3	32.5	31.5	30.6	29.5	28.2	26.7	26	25.2	23.1	21.9
TD250-32/4	90	120		38.9	38.2	37.3	36.3	35.3	34.2	32.7	32	31.2	29.3	28.2
TD250-40/4	110	150		46.4	45.8	45.2	44.4	43.6	42.4	40.8	40	39	36.5	34.9
TD250-50/4	132	180		56.1	55.7	55.1	54.4	53.6	52.5	50.8	50	48.9	46.3	44.8

Installation sketch

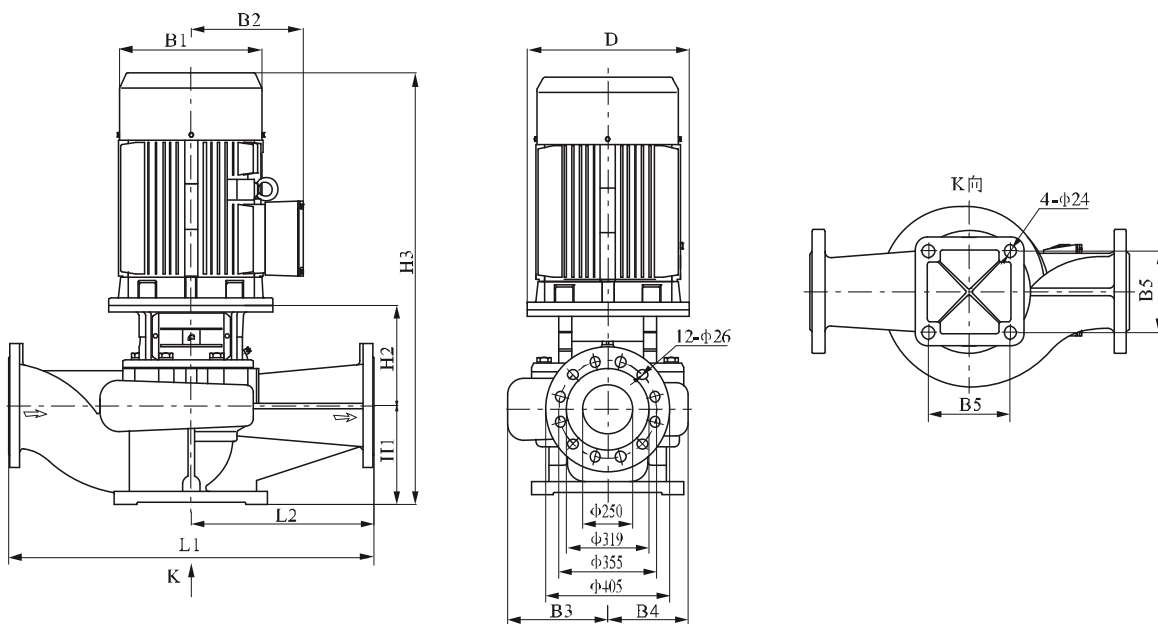

Dimensions and weights

Model	Dimension(mm)											Weight (kg)
	D	B1	B2	B3	B4	B5	H1	H2	H3	L1	L2	
TD250-14/4	450	450	335	316	243	390	300	495	1469	1100	550	610
TD250-17/4	450	450	335	316	243	390	300	495	1492	1100	550	647
TD250-20/4	550	490	365	316	243	390	300	495	1568	1100	550	720
TD250-26/4	550	550	400	329	264	440	300	507	1636	1100	550	906
TD250-32/4	550	550	400	329	264	440	300	507	1687	1100	550	997
TD250-40/4	660	625	555	347	292	440	305	525	1840	1200	600	1386
TD250-50/4	660	625	555	347	292	440	305	525	1990	1200	600	1469

Note: The dimension of single-phase motor and explosion-proof motor will change. Please consult our company for more details.

Performance curve

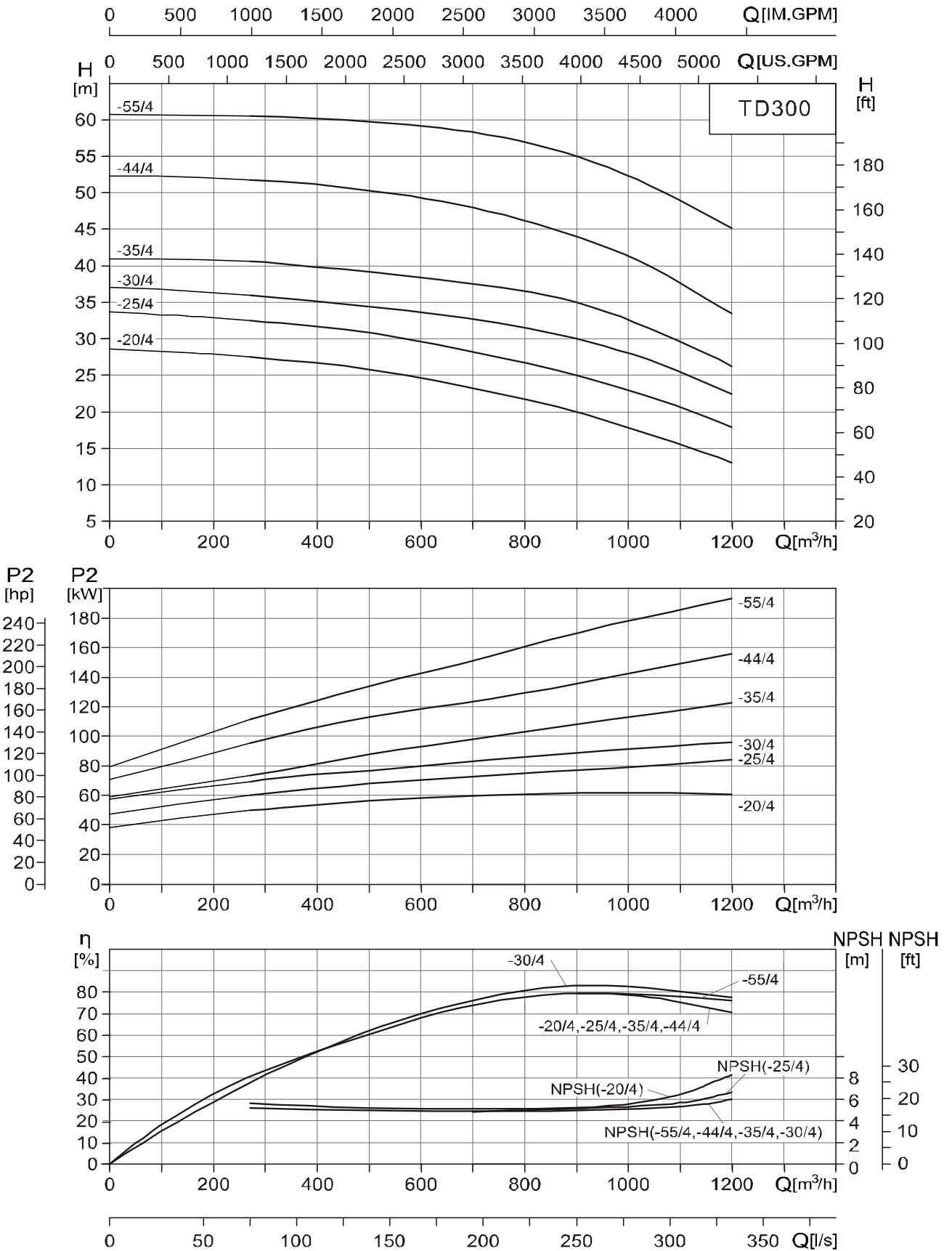

TD300 Performance table

60Hz

Model	Motor		Q (m ³ /h)	270	360	450	630	750	900	1080	1200
	(kW)	(hp)									
TD300-20/4	75	100	H (m)	27.5	27	26.3	24.3	22.5	20	16	13
TD300-25/4	90	120		32.5	32	31.3	29.3	27.6	25	21.1	17.9
TD300-30/4	110	150		36	35.4	34.8	33.4	32.1	30	26	22.4
TD300-35/4	132	180		40.6	40	39.6	38.2	37	35	30.2	26.3
TD300-44/4	160	215		51.8	51.3	50.7	49	47.1	44	38.5	33.5
TD300-55/4	200	270		60.5	60.3	60	58.9	57.7	55	49.6	45

Installation sketch

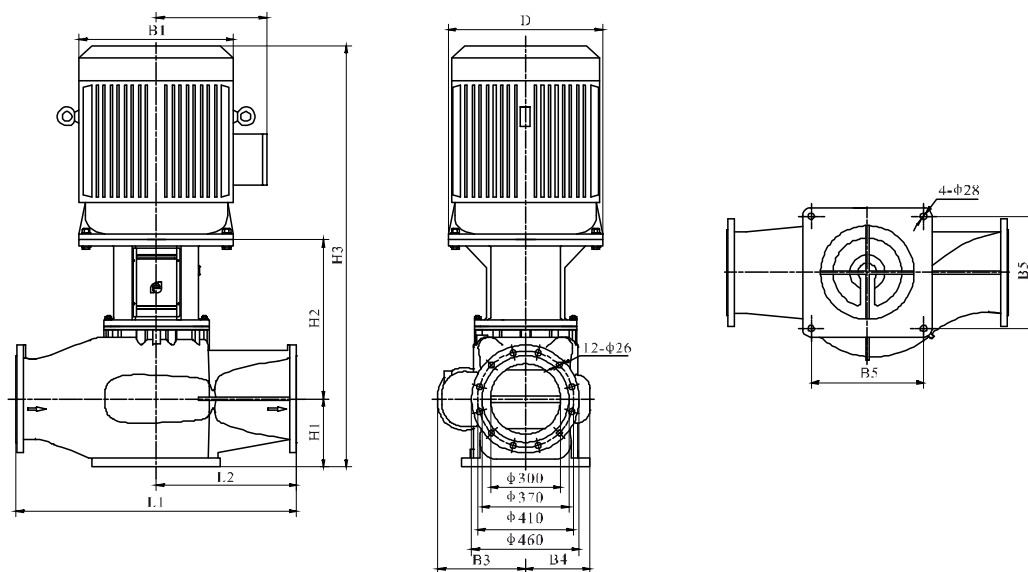

Dimensions and weights

Model	Dimension(mm)											Weight (kg)
	D	B1	B2	B3	B4	B5	H1	H2	H3	L1	L2	
TD300-20/4	550	550	400	345	250	440	290	649	1770	1200	600	1070
TD300-25/4	550	550	400	345	250	440	290	649	1820	1200	600	1120
TD300-30/4	660	625	555	345	250	440	290	679	2200	1200	600	1460
TD300-35/4	660	625	555	345	250	440	290	679	2150	1200	600	1540
TD300-44/4	660	625	550	380	295	480	290	702	2150	1200	600	1780
TD300-55/4	660	625	550	380	295	480	290	702	2150	1200	600	1900

Note: The dimension of single-phase motor and explosion-proof motor will change. Please consult our company for more details.



Hong Kong Nanfang Pump Industry Co., Ltd.

Address: Room 5, Flat A, 14/F,

Lee Chung Industrial Building,

7-9 Tst Po Street, San Po Kong, Kowloon.

Tel: 3460 3447

Fax: 3460 4151

Email: info@hkcnpump.com

Website: www.hkcnpump.com